



South Carolina Department of Labor, Licensing and Regulation
South Carolina Building Codes Council
 110 Centerview Dr • Columbia • SC • 29210
 P.O. Box 11329 • Columbia • SC • 29211-1329
 Phone: 803-896-4688 • contact.bcc@llr.sc.gov • Fax: 803-896-4814
llr.sc.gov/bcc

2021 MODIFICATION INDEX

*Modification Index numbers below are hyperlinked to the referenced modifications. The LLR logo on each modification page links back to index.

MODIFICATION INDEX NUMBER	CODE SECTION	REQUESTING ASSOCIATION/ JURISDICTION	NEW/ CONTINUATION
2021 IBC			
IBC 2021-01	[A] 101.4.7 Existing Buildings	American Concrete Institute (ACI)	New
IBC 2021-02	202 Definitions	BOASC	Continuation
IBC 2021-04	303.4 Assembly Group A-3	BOASC	Continuation
IBC 2021-05	312.1 General "Primitive Camp Structure"	BOASC	Continuation
IBC 2021-07	706.1 General	BOASC	Continuation
IBC 2021-10	1010.2.14 Controlled egress doors in Groups I-1 and I-2 (also in IFC)	Midlands Fire Marshal's Association	New
IBC 2021-11	1016.2 Egress through intervening spaces	BOASC	Continuation
IBC 2021-14	1803.2 Investigations required	BOASC	Continuation
IBC 2021-16	1907.1 General	Structural Engineers	Continuation
IBC 2021-17	2303.2.2 Other means during manufacture	BOASC	Continuation
IBC 2021-18	Appendix H Signs	Structural Engineers	Continuation
2021 IRC			
IRC 2021-01	R202 Definitions - Accepted Eng. Practice	Coastal Code Enforcement Association of SC	Continuation
IRC 2021-02	R202 Definitions - Crawl Space	HBA of SC	New
IRC 2021-04	R301.2.1 Wind Design Criteria	HBA of SC	New
IRC 2021-05	R301.2.2.1 Determination of seismic design category	HBA of SC	New
IRC 2021-06	R302.1 Exterior Walls (Add Exception 6)	Coastal Code Enforcement Association of SC	Continuation
IRC 2021-07	R302.1 Exterior Walls (Add Exception 7)	BOASC	New
IRC 2021-09	R302.4.1 Through penetrations	BOASC	New
IRC 2021-10	R302.5.1 Opening protection	HBA of SC	Continuation
IRC 2021-11	R302.13 Fire Protection of floors	HBA of SC	Continuation
IRC 2021-12	R303.4 Mechanical ventilation	Coastal Code Enforcement Association of SC	Continuation
IRC 2021-13	Figure R307.1 Minimum Fixture Clearances	HBA of SC	Continuation
IRC 2021-15	R311.7.5.1 Risers	Structural Engineers Association of SC	Continuation
IRC 2021-16	R312.1.1 Where required	HBA of SC	Continuation
IRC 2021-17	R312.2 Window fall protection	HBA of SC	Continuation
IRC 2021-18	R313 Automatic Fire Sprinkler Systems	HBA of SC	Continuation
IRC 2021-22	R317.1.1 Field treatment	Structural Engineers Association of SC	Continuation
IRC 2021-23	R318.1 Subterranean termite control methods	HBA of SC	Continuation
IRC 2021-24	R318.4 Foam Plastic Protection	HBA of SC	Continuation
IRC 2021-25	R318.5 Termite Inspection Strip	HBA of SC	New
IRC 2021-28	R322.1 General	BOASC	Continuation
IRC 2021-29	R326.3 Story above grade plane	HBA of SC	New
IRC 2021-31	R404.1.9.2 Masonry Piers Supporting floor girders	HBA of SC & Structural Engineers Association of SC	Continuation

MODIFICATION INDEX NUMBER	CODE SECTION	REQUESTING ASSOCIATION/ JURISDICTION	NEW/ CONTINUATION
IRC 2021-32	R408.3 Unvented Crawl Space	Structural Engineers Association of SC	Continuation
IRC 2021-33	R408.3(2.2) Unvented crawl space	HBA of SC	New
IRC 2021-34	R408.4 Access	HBA of SC	Continuation
IRC 2021-35	R408.8 Under-floor vapor retarder	HBA of SC	New
IRC 2021-36	R502.11.4 Truss design drawings	HBA of SC	Continuation
IRC 2021-37	R506.2.3 Vapor retarder	Structural Engineers Association of SC	Continuation
IRC 2021-38	R606.7 Piers	Structural Engineers Association of SC	Continuation
IRC 2021-39	R802.10.1 Truss design drawings	HBA of SC	Continuation
IRC 2021-40	R905.2.8.5 Drip Edge	HBA of SC	Continuation
IRC 2021-41	Chapter 11 Energy Efficiency	HBA of SC	Continuation
IRC 2021-42	M1411.6 Insulation of refrigerant piping	HBA of SC	Continuation
IRC 2021-43	M1411.9 Locking access port caps	HBA of SC	Continuation
IRC 2021-44	M1502.3 Duct termination	HBA of SC	Continuation
IRC 2021-45	M1502.4.2 Duct Installation	HBA of SC	Continuation
IRC 2021-46	M1502.4.6 Duct length	HBA of SC	Continuation
IRC 2021-47	M1503.6 Makeup air	HBA of SC	Continuation
IRC 2021-48	M1504.3 Exhaust Openings	HBA of SC	Continuation
IRC 2021-49	M1601.4.1 Joints, Seams and Connections	HBA of SC	Continuation
IRC 2021-50	G2418.2 Design and installation	HBA of SC	Continuation
IRC 2021-51	P2503.6 Shower liner test	HBA of SC	Continuation
IRC 2021-52	P2503.6 Shower liner test	HBA of SC	New (Adds to continuation)
IRC 2021-53	P2603.2.1 Protection against physical damage	HBA of SC	New
IRC 2021-54	P2603.5 Freezing	HBA of SC	Continuation
IRC 2021-55	P2603.5 Freezing	HBA of SC	New (Adds to continuation)
IRC 2021-56	P2705.1 (3) General	HBA of SC	New
IRC 2021-57	P2708.4 Shower control valves	HBA of SC	New
IRC 2021-58	P2713.3 Bathtub and whirlpool bathtub valves	HBA of SC	New
IRC 2021-60	P2903.10 Hose bibb	HBA of SC	Continuation
IRC 2021-62	P2904.2.4.2.1 Additional requirements for pendant sprinklers	SC Master Plumbers Association	New
IRC 2021-66	E3606.5 Surge Protection	HBA of SC	New
IRC 2021-67	E3802.4 In unfinished basements	HBA of SC	Continuation
IRC 2021-69	E3901.4.2 (1) – Island and peninsular countertops and work spaces	HBA of SC	New
IRC 2021-70	E3902 Ground-Fault & Arc-Fault Circuit-Interrupter Protection	HBA of SC	New
IRC 2021-71	E3902.5 Basement Receptacles	HBA of SC	New
IRC 2021-73	E3902.17 Arc-Fault Circuit Interrupter Protection	HBA of SC	Continuation
IRC 2021-75	E4002.14 Tamper-resistant receptacles	HBA of SC	New
IRC 2021-76	Chapter 44 Referenced Standards	AHRI	New
IRC 2021-77	Appendix AH Patio Covers	Structural Engineers Association of SC	Continuation
IRC 2021-78	Appendix AJ Existing Buildings and Structures	Structural Engineers Association of SC	Continuation
IRC 2021-79	Appendix AQ Tiny Houses	BOASC	Continuation

MODIFICATION INDEX NUMBER	CODE SECTION	REQUESTING ASSOCIATION/ JURISDICTION	NEW/ CONTINUATION
2021 IFC			
IFC 2021-02	202 General definitions - Primitive camp structure	BOASC	Continuation
IFC 2021-03	202 General definitions - A-3 occupancies	BOASC	Continuation
IFC 2021-04	202 General definitions - Recreational Fire	SC Fire Marshal's Association	Continuation
IFC 2021-05	315.3.3 Equipment rooms	Midlands Fire Marshal's Association	New
IFC 2021-07	319.11 Clearance requirements (New Section)	Midlands Fire Marshal's Association	New
IFC 2021-08	503.1.2 Additional Access	HBA of SC	New
IFC 2021-09	503.1.2.1 One- or two-family dwelling residential developments having less than 50 units (New section)	HBA of SC	New
IFC 2021-10	503.2.1 Dimensions	HBA of SC	Continuation
IFC 2021-11	507.1 Required water supply	Charleston Fire Department	Continuation
IFC 2021-12	507.5.1 Where Required	Charleston Fire Department	Continuation
IFC 2021-13	507.5.1.1 Hydrant for standpipe systems	Midlands Fire Marshal's Association	New
IFC 2021-14	507.5.4 Obstruction	Midlands Fire Marshal's Association	New
IFC 2021-16	607.1 General	Midlands Fire Marshal's Association	New
IFC 2021-19	901.6.3 Records	Charleston Fire Department	Continuation
IFC 2021-22	907.6.5 Access	Midlands Fire Marshal's Association	New
IFC 2021-24	1010.2.14 Controlled egress doors in Groups I-1 and I-2 (Also in IBC)	Midlands Fire Marshal's Association	New
IFC 2021-25	1016.2 Egress through intervening spaces	Charleston Fire Department	Continuation
IFC 2021-31	2303.2.2 Testing (New section)	Midlands Fire Marshal's Association	New
IFC 2021-33	2305.5 Fire extinguishers	Midlands Fire Marshal's Association	New
IFC 2021-34	2307.4 Location of dispensing operations and equipment	SCPGA	Continuation
IFC 2021-35	2307.7 Public fueling of motor vehicles	SCPGA	Continuation
IFC 2021-38	6101.1 Scope	SC Fire Marshal's Association	Continuation
IFC 2021-41	6106.1 Attendants	SC Fire Marshal's Association	Continuation
IFC 2021-42	6107.4 Protecting containers from vehicles	SC Fire Marshal's Association	Continuation
IFC 2021-43	6109.13 Protection of containers	SC Fire Marshal's Association	Continuation
IFC 2021-44	6110.1 Removed from service	SC Fire Marshal's Association	Continuation
IFC 2021-45	6111.2.1 Near residential, educational and institutional occupancies and other high-risk areas	SC Fire Marshal's Association	Continuation
2021 IPC			
IPC 2021-01	202 General Definitions - Drinking Fountain	Carolinas AGC	New
IPC 2021-02	202 General Definitions - Bottle Filling Station	Carolinas AGC	New
IPC 2021-03	202 General Definitions - Water Cooler	Carolinas AGC	New
IPC 2021-04	202 General Definitions - Water Dispenser	Carolinas AGC	New
IPC 2021-05	Table 403.1 Minimum number of required plumbing fixtures	Carolinas AGC	New
IPC 2021-06	410.4 Substitution	Carolinas AGC	New
2021 IMC			
IMC 2021-01	504.9.2 Duct Installation	BOASC	Continuation
IMC 2021-02	Table 1103.1 Refrigerant Classification Amount and OEL	AHRI	New

MODIFICATION INDEX NUMBER	CODE SECTION	REQUESTING ASSOCIATION/ JURISDICTION	NEW/ CONTINUATION
IMC 2021-03	1104.3 System Application Requirements	AHRI	New
IMC 2021-04	Chapter 15 Referenced Standards	AHRI	New
2021 IFGC			
IFGC 2021-01	401.9 Identification	SCPGA	Continuation
IFGC 2021-02	401.10 Third-party testing and certification	SCPGA	Continuation
IFGC 2021-03	412.4 Listed equipment	SCPGA	Continuation
IFGC 2021-04	412.6 Location	SCPGA	Continuation
IFGC 2021-05	412.8.3 Vehicle impact protection	SCPGA	Continuation
IFGC 2021-06	412.10 Private fueling of motor vehicles	SCPGA	Continuation
IFGC 2021-07	505.1.1 Commercial cooking appliances vented by exhaust hoods	Piedmont Natural gas	Continuation
2020 NEC			
NEC 2020-03	210.8(A)(5) Basements	HBA of SC	New
NEC 2020-04	210.8(F) Outdoor Outlets	HBA of SC	New
NEC 2020-05	210.12 Arc-Fault Circuit-Interpreter Protection	HBA of SC	New
NEC 2020-06	230.67 Surge Protection	HBA of SC	New



South Carolina Department of Labor, Licensing and Regulation
South Carolina Building Codes Council
2021 Modification Index

Applicable Code: 2021 International Building Code

Modification Index Number: IBC 2021-01

Code Section: [A] 101.4.7 Existing Buildings

Modification:

[A] 101.4.7 Existing buildings. The provisions of the International Existing Building Code shall apply to matters governing the repair, alternation, change of occupancy, addition to and relocation of existing buildings.

101.4.7.1 Structural concrete. In addition, assessment, repairs, and restoration of structural concrete in accordance with ACI 562 shall be permitted.

Exception:
ACI 562 shall not be used for the evaluation or design of repairs or rehabilitation of elements of seismic force-resisting system that result in strength, stiffness, or ductility of those elements different from the pre-damage condition.

Add new referenced standard to Chapter 16 as follows:

ACI American Concrete Institute
38800 Country Club Drive
Farmington Hills, MI 48331
Standard reference number Title Referenced in code section number
562-19 Code Requirements for Assessment, Repair, and Rehabilitation of Existing Concrete Structures
101.4.7.1

Proponent: American Concrete Institute (ACI)

Previous Code Cycles	Previous Modification Index Number	Previous Code Section
n/a		



South Carolina Department of Labor, Licensing and Regulation
South Carolina Building Codes Council
2021 Modification Index

Applicable Code: 2021 International Building Code

Modification Index Number: IBC 2021-02

Code Section: 202 Definitions

Modification:

VAPOR RETARDER, GROUND CONTACT. Ground contact vapor retarder class shall be defined using the requirements of ASTM E1745, Class A, B, or C-Standard specification for water vapor retarders used in contact with soil or granular fill under concrete slabs.

PRIMITIVE CAMP STRUCTURE. Shall include any structure permanent or temporary in nature, used for outdoor camping (transient), open on at least one side with no fully enclosed habitable spaces, less than 400 square feet (37 m2) under roof, and not classified as a residential occupancy due to lack of electrical, plumbing, mechanical and sprinkler systems.

Proponent: BOASC

Previous Code Cycles	Previous Modification Index Number	Previous Code Section
IBC 2018	IBC 2018 01	202



South Carolina Department of Labor, Licensing and Regulation
South Carolina Building Codes Council
2021 Modification Index

Applicable Code: 2021 International Building Code

Modification Index Number: IBC 2021-04

Code Section: 303.4 Assembly Group A-3

Modification:

303.4 Assembly Group A-3. Group A-3 occupancy includes assembly uses intended for worship, recreation or amusement and other assembly uses not classified elsewhere in Group A including, but not limited to:

- Amusement arcades
- Art galleries
- Bowling alleys
- Community halls
- Courtrooms
- Dance halls (not including food or drink consumption)
- Exhibition halls
- Funeral parlors
- Greenhouses* for the conservation and exhibition of plants that provide public access
- Gymnasiums (without spectator seating)
- Indoor *swimming pools* (without spectator seating)
- Indoor tennis courts (without spectator seating)
- Lecture halls
- Libraries
- Museums
- Places of religious worship*
- Pool and billiard parlors
- Structures, without a commercial kitchen, used in agritourism activity as defined by S.C. Code Ann. 46-53-10(1)
- Waiting areas in transportation terminals

Proponent: BOASC

Previous Code Cycles	Previous Modification Index Number	Previous Code Section
IBC 2018	IBC 2018 02	303.4



South Carolina Department of Labor, Licensing and Regulation
South Carolina Building Codes Council
2021 Modification Index

Applicable Code: 2021 International Building Code

Modification Index Number: IBC 2021-05

Code Section: 312.1 General.

Modification:

SECTION 312

UTILITY AND MISCELLANEOUS GROUP U

312.1 General. Buildings and structures of an accessory character and miscellaneous structures not classified in any specific occupancy shall be constructed, equipped and maintained to conform to the requirements of this code commensurate with the fire and life hazard incidental to their occupancy. Group U shall include, but not be limited to, the following:

Agricultural buildings

Aircraft hangars, accessory to a one- or two-family residence (see Section 412.4)

Barns

Carports

Communication equipment structures with a *gross floor area* of less than 1,500 square feet (139 m²)

Fences more than 7 feet (2134 mm) in height

Grain silos, accessory to a residential occupancy

Livestock shelters

Primitive Camp Structures

Private garages

Retaining walls

Sheds

Stables

Tanks

Towers

Proponent: BOASC

Previous Code Cycles	Previous Modification Index Number	Previous Code Section
IBC 2018	IBC 2018 03	312.1



South Carolina Department of Labor, Licensing and Regulation
South Carolina Building Codes Council
2021 Modification Index

Applicable Code: 2021 International Building Code

Modification Index Number: IBC 2021-07

Code Section: 706.1 General

Modification:

706.1 General. *Fire walls* shall be constructed in accordance with Sections 706.2 through 706.11. Each portion of a building separated by one or more firewalls may be considered a separate building. The extent and location of such *fire walls* shall provide a complete separation. Where a *fire wall* separates occupancies that are required to be separated by a *fire barrier* wall, the most restrictive requirements of each separation shall apply.

Proponent: BOASC

Previous Code Cycles	Previous Modification Index Number	Previous Code Section
IBC 2018	IBC 2018 05	706.1



South Carolina Department of Labor, Licensing and Regulation
South Carolina Building Codes Council
2021 Modification Index

Applicable Code: 2021 International Building Code

Modification Index Number: IBC 2021-10

Code Section: 1010.2.14 Controlled egress doors in Group I-1 and I-2

Modification:

1010.2.14 Controlled egress doors in Groups I-1, I-2, and I-4 (Adult Day Care Occupancy only).

Electric locking systems, including electro-mechanical locking systems and electromagnetic locking systems, shall be permitted to be locked in the means of egress in Group I-1, I-2, and I-4 (Adult Day Care occupancy only) occupancies where the clinical needs of persons receiving care require their containment. Controlled egress doors shall be permitted in such occupancies where the building is equipped throughout with an automatic sprinkler system in accordance with Section 903.3.1.1 or an approved automatic smoke detection system installed in accordance with Section 907, provided that the doors are installed and operate in accordance with all of the following:

1. The door locks shall unlock on actuation of the automatic sprinkler system or automatic smoke detection system.
2. The door locks shall unlock on loss of power controlling the lock or lock mechanism.
3. The door locking system shall be installed to have the capability of being unlocked by a switch located at the fire command center, a nursing station or other approved location. The switch shall directly break power to the lock.
4. A building occupant shall not be required to pass through more than one door equipped with a controlled egress locking system before entering an exit.
5. The procedures for unlocking the doors shall be described and approved as part of the emergency planning and preparedness required by Chapter 4 of the International Fire Code.
6. All clinical staff shall have the keys, codes or other means necessary to operate the locking systems.
7. Emergency lighting shall be provided at the door.
8. The door locking system units shall be listed in accordance with UL 294.

Exceptions:

1. Items 1 through 4 shall not apply to doors to areas occupied by persons who, because of clinical needs, require restraint or containment as part of the function of a psychiatric or cognitive treatment area.
2. Items 1 through 4 shall not apply to doors to areas where a listed egress control system is utilized to reduce the risk of child abduction from nursery and obstetric areas of a Group I-2 hospital.

Proponent: Midlands Fire Marshal's Association

Previous Code Cycles	Previous Modification Index Number	Previous Code Section
n/a		



South Carolina Department of Labor, Licensing and Regulation
South Carolina Building Codes Council
2021 Modification Index

Applicable Code: 2021 International Building Code

Modification Index Number: IBC 2021-11

Code Section: 1016.2 Egress through intervening spaces

Modification:

1016.2 Egress through intervening spaces. Egress through intervening spaces shall comply with this section.

1. Exit access through an enclosed elevator lobby is permitted. Where access to two or more exits or exit access doorways is required in Section 1006.2.1, access to not less than one of the required exits shall be provided without travel through the enclosed elevator lobbies required by Section 3006 of the South Carolina Building Code. Where the path of exit access travel passes through an enclosed elevator lobby, the level of protection required for the enclosed elevator lobby is not required to be extended to the exit unless direct access to an exit is required by other sections of this code.
2. Egress from a room or space shall not pass through adjoining or intervening rooms or areas, except where such adjoining rooms or areas and the area served are accessory to one or the other, are not a Group H occupancy and provide a discernible path of egress travel to an exit.

 Exception: Means of egress are not prohibited through adjoining or intervening rooms or spaces in a Group H, S or F occupancy where the adjoining or intervening rooms or spaces are the same or a lesser hazard occupancy group.
3. An exit access shall not pass through a room that can be locked to prevent egress.
4. Means of egress from dwelling units or sleeping areas shall not lead through other sleeping areas, toilet rooms or bathrooms.

 Exception: Dwelling units or sleeping areas in R-1 and R-2 occupancies shall be permitted to egress through other sleeping areas serving adjoining rooms that are part of the same dwelling unit or guest room.
5. Egress shall not pass through kitchens, storage rooms, closets or spaces used for similar purposes.

 Exceptions:
 1. Means of egress are not prohibited through a kitchen area serving adjoining rooms constituting part of the same dwelling unit or sleeping unit.
 2. Means of egress are not prohibited through stockrooms in Group M occupancies where all of the following are met:
 - 2.1. The stock is of the same hazard classification as that found in the main retail area.
 - 2.2. Not more than 50 percent of the exit access is through the stockroom.
 - 2.3. The stockroom is not subject to locking from the egress side.
 - 2.4. There is a demarcated, minimum 44-inch-wide (1118 mm) aisle defined by ~~full- or partial-height fixed walls~~ a wall not less than 42 inches (1067 mm) high or similar construction that will maintain the required width and lead directly from the retail area to the exit without obstructions.

Proponent: BOASC

Previous Code Cycles	Previous Modification Index Number	Previous Code Section
IBC 2018	IBC 2018 10	1016.2



South Carolina Department of Labor, Licensing and Regulation
South Carolina Building Codes Council
2021 Modification Index

Applicable Code: 2021 International Building Code

Modification Index Number: IBC 2021-14

Code Section: 1803.2 Investigations required

Modification:

1803.2 Investigations required. Geotechnical investigations shall be conducted in accordance with Sections 1803.3 through 1803.5.

Exceptions:

1. The building official shall be permitted to waive the requirement for a geotechnical investigation where satisfactory data from adjacent areas is available that demonstrates an investigation is not necessary for any of the conditions in Sections 1803.5.1 through 1803.5.6 and Sections 1803.5.10 and 1803.5.11.

2. For single story buildings not more than 5,000 square feet (465 m2) and not more than 30 feet (9144 mm) in height, a site specification investigation report is not required if the seismic design category is determined by the design professional in accordance with Chapter 20 of ASCE 7.

Proponent: BOASC

Previous Code Cycles	Previous Modification Index Number	Previous Code Section
IBC 2018	IBC 2018 11	1803.2



South Carolina Department of Labor, Licensing and Regulation
South Carolina Building Codes Council
2021 Modification Index

Applicable Code: 2021 International Building Code

Modification Index Number: IBC 2021-16

Code Section: 1907.1 General

Modification:

SECTION 1907

MINIMUM SLAB PROVISIONS

1907.1 General. The thickness of concrete floor slabs supported directly on the ground shall be not less than 3½ inches (89 mm). A 6-mil (0.006 inch; 0.15 mm) 10-mil (0.010 inch) polyethylene ground contact vapor retarder with joints lapped not less than 6 inches (152 mm) shall be placed between the base course or subgrade and the concrete floor slab, or other *approved* equivalent methods or materials shall be used to retard vapor transmission through the floor slab.

Exceptions: A vapor retarder is not required:

1. For detached structures accessory to occupancies in Group R-3, such as garages, utility buildings or other unheated facilities.
2. For unheated storage rooms having an area of less than 70 square feet (6.5 m²) and carports attached to occupancies in Group R-3.
3. For buildings of other occupancies where migration of moisture through the slab from below will not be detrimental to the intended occupancy of the building.
4. For driveways, walks, patios and other flatwork that will not be enclosed at a later date.
5. Where *approved* based on local site conditions.

Proponent: Structural Engineers' Association of SC

Previous Code Cycles	Previous Modification Index Number	Previous Code Section
IBC 2018	IBC 2018 12	1907.1



South Carolina Department of Labor, Licensing and Regulation
South Carolina Building Codes Council
2021 Modification Index

Applicable Code: 2021 International Building Code

Modification Index Number: IBC 2021-17

Code Section: 2303.2.2 Others means during manufacture

Modification:

2303.2.2 Other means during manufacture. For wood products impregnated with chemicals by other means during manufacture, the treatment shall be an integral part of the manufacturing process of the wood product. The treatment shall provide permanent protection to all surfaces of the wood product. ~~The use of paints, coating, stains or other surface treatments is not an approved method of protection as required in this section.~~

Proponent: BOASC

Previous Code Cycles	Previous Modification Index Number	Previous Code Section
IBC 2018	IBC 2018 13	2303.2.2



South Carolina Department of Labor, Licensing and Regulation
South Carolina Building Codes Council
2021 Modification Index

Applicable Code: 2021 International Building Code

Modification Index Number: IBC 2021-18

Code Section: Appendix H Signs

Modification:

Appendix H Signs
The provisions in Appendix H are adopted for use statewide.

Appendix H gathers in one place the various code standards that regulate the construction and protection of outdoor signs. Whenever possible, this appendix provides standards in performance language, thus allowing the widest possible application.

Proponent: Structural Engineers Association of South Carolina

Previous Code Cycles	Previous Modification Index Number	Previous Code Section
IBC 2018	IBC 2018 14	Appendix H
IBC 2015	IBC 2015 07	Appendix H
IBC 2012	IBC 2012 05	Appendix H



South Carolina Department of Labor, Licensing and Regulation
South Carolina Building Codes Council
2021 Modification Index

Applicable Code: 2021 International Residential Code

Modification Index Number: IRC 2021-01

Code Section: R202 Definitions

Modification:

ACCEPTED ENGINEERING PRACTICE - The performance design of structures and/or structural elements that vary from prescriptive design methods of this code. Such design shall be made with accepted design standards by a South Carolina licensed Architect or Engineer as permitted by existing state law.

Proponent: Coastal Code Enforcement Association of SC

Previous Code Cycles	Previous Modification Index Number	Previous Code Section
IRC 2018	IRC 2018 01	R202 Definitions
IRC 2015	IRC 2015 01	R202 Definitions
IRC 2012	IRC 2012 01	R202 Definitions



South Carolina Department of Labor, Licensing and Regulation
South Carolina Building Codes Council
2021 Modification Index

Applicable Code: 2021 International Residential Code

Modification Index Number: IRC 2021-02

Code Section: R202 Definitions

Modification:

[RB] CRAWL SPACE. An underfloor space that is not a *basement*. Spaces under decks and porches that do not contain mechanical equipment are not to be considered crawlspaces.

Proponent: Home Builders Association of South Carolina

Previous Code Cycles	Previous Modification Index Number	Previous Code Section
N/A		



South Carolina Department of Labor, Licensing and Regulation
South Carolina Building Codes Council
2021 Modification Index

Applicable Code: 2021 International Residential Code

Modification Index Number: IRC 2021-04

Code Section: R301.2.1 Wind design criteria

Modification:

R301.2.1 Wind design criteria. Buildings and portions thereof shall be constructed in accordance with the wind provisions of this code using the ultimate design wind speed in Table R301.2 as determined from Figure R301.2(2) the previously published maps by the South Carolina Building Codes Council. The local building official may delineate the wind design category within their jurisdiction, as long as, it does not surpass those provided on the Applied Technology Council (ATC) website. The structural provisions of this code for wind loads are not permitted where wind design is required as specified in Section R301.2.1.1. Where different construction methods and structural materials are used for various portions of a building, the applicable requirements of this section for each portion shall apply. Where not otherwise specified, the wind loads listed in Table R301.2.1(1) adjusted for height and exposure using Table R301.2.1(2) shall be used to determine design load performance requirements for wall coverings, curtain walls, roof coverings, exterior windows, skylights, garage doors and exterior doors. Asphalt shingles shall be designed for wind speeds in accordance with Section R905.2.4. *Metal roof shingles* shall be designed for wind speeds in accordance with Section R905.4.4. A continuous load path shall be provided to transmit the applicable uplift forces in Section R802.11 from the *roof assembly* to the foundation. Where ultimate design wind speeds in Figure R301.2(2) are less than the lowest wind speed indicated in the prescriptive provisions of this code, the lowest wind speed indicated in the prescriptive provisions of this code shall be used.

Proponent: Home Builders Association of South Carolina

Previous Code Cycles	Previous Modification Index Number	Previous Code Section
N/A		



South Carolina Department of Labor, Licensing and Regulation
South Carolina Building Codes Council
2021 Modification Index

Applicable Code: 2021 International Residential Code

Modification Index Number: IRC 2021-05

Code Section: R301.2.2.1 Determination of seismic design category

Modification:

R301.2.2.1 Determination of seismic design category. Buildings shall be assigned a seismic design category in accordance with the previously published maps by the South Carolina Building Codes Council. ~~Figures R301.2.2.1(1) through R301.2.2.1(6).~~ The local building official may delineate the seismic design category within the jurisdiction, as long as, it does not surpass those provided on the Applied Technology Council (ATC) website.

Proponent: Home Builders Association of South Carolina

Previous Code Cycles	Previous Modification Index Number	Previous Code Section
N/A		



South Carolina Department of Labor, Licensing and Regulation
South Carolina Building Codes Council
2021 Modification Index

Applicable Code: 2021 International Residential Code

Modification Index Number: IRC 2021-06

Code Section: R302.1 Exterior walls

Modification:

R302.1 Exterior walls. Construction, projections, openings and penetrations of exterior walls of *dwelling*s and accessory buildings shall comply with Table R302.1(1); or *dwelling*s equipped throughout with an *automatic sprinkler system* installed in accordance with Section P2904 shall comply with Table R302.1(2).

Exceptions:

1. Walls, projections, openings or penetrations in walls perpendicular to the line used to determine the *fire separation distance*.
2. Walls of *individual dwelling units* and their *accessory structures* located on the same *lot*.
3. Detached tool sheds and storage sheds, playhouses and similar structures exempted from *permits* are not required to provide wall protection based on location on the *lot*. Projections beyond the exterior wall shall not extend over the *lot line*.
4. Detached garages accessory to a *dwelling* located within 2 feet (610 mm) of a *lot line* are permitted to have roof eave projections not exceeding 4 inches (102 mm).
5. Foundation vents installed in compliance with this code are permitted.
6. Fire separation distance.
 - a. The minimum fire separation distance for improvement constructed on a lot shown on: [i] a recorded bonded or final subdivision plat, or [ii] a sketch plan, site plan, plan of phased development or preliminary plat approved by the local governing authority, which was recorded or approved prior to the implementation of 2012 International Residential Code and which shows or describes lesser setbacks than the fire separation distances provided in Table R302.1(1), shall be equal to the lesser setbacks, but in no event less than 3 feet (914 mm).
 - b. The minimum fire separation distance for improvements constructed on a lot where the local governing authority has, prior to the implementation of 2012 International Residential Code: [i] accepted exactions or issued conditions, [ii] granted a special exception, [iii] entered into a development agreement, [iv] approved a variance, [v] approved a planned development district, or [vi] otherwise approved a specific development plan which contemplated or provided for setbacks less than the fire separation distances provided in Table R302.1(1), shall be equal to the lesser setback, but in no event less than 3 feet (914 mm).

Proponent: Coastal Code Enforcement Association of South Carolina

Previous Code Cycles	Previous Modification Index Number	Previous Code Section
IRC 2018	IRC 2018 04	R302.1
IRC 2015	IRC 2015 01	R302.1
IRC 2012	IRC 2012 02	R302.1



South Carolina Department of Labor, Licensing and Regulation
South Carolina Building Codes Council
2021 Modification Index

Applicable Code: 2021 International Residential Code

Modification Index Number: IRC 2021-07

Code Section: R302.1 Exterior walls

Modification:

R302.1 Exterior walls. Construction, projections, openings and penetrations of exterior walls of *dwelling*s and accessory buildings shall comply with Table R302.1(1); or *dwelling*s equipped throughout with an *automatic sprinkler system* installed in accordance with Section P2904 shall comply with Table R302.1(2).

Exceptions:

1. Walls, projections, openings or penetrations in walls perpendicular to the line used to determine the *fire separation distance*.
2. Walls of *individual dwelling units* and their *accessory structures* located on the same *lot*.
3. Detached tool sheds and storage sheds, playhouses and similar structures exempted from *permits* are not required to provide wall protection based on location on the *lot*. Projections beyond the exterior wall shall not extend over the *lot line*.
4. Detached garages accessory to a *dwelling* located within 2 feet (610 mm) of a *lot line* are permitted to have roof eave projections not exceeding 4 inches (102 mm).
5. Foundation vents installed in compliance with this code are permitted.
6. Fire separation distance.
 - a. The minimum fire separation distance for improvement constructed on a lot shown on: [i] a recorded bonded or final subdivision plat, or [ii] a sketch plan, site plan, plan of phased development or preliminary plat approved by the local governing authority, which was recorded or approved prior to the implementation of 2012 International Residential Code and which shows or describes lesser setbacks than the fire separation distances provided in Table R302.1(1), shall be equal to the lesser setbacks, but in no event less than 3 feet (914 mm).
 - b. The minimum fire separation distance for improvements constructed on a lot where the local governing authority has, prior to the implementation of 2012 International Residential Code: [i] accepted exactions or issued conditions, [ii] granted a special exception, [iii] entered into a development agreement, [iv] approved a variance, [v] approved a planned development district, or [vi] otherwise approved a specific development plan which contemplated or provided for setbacks less than the fire separation distances provided in Table R302.1(1), shall be equal to the lesser setback, but in no event less than 3 feet (914 mm).
7. Aesthetic roof and siding projections may extend beyond the common wall of a townhouse unit over an adjoining unit's property line as long as the construction of the projection does not damage the integrity of the fire-rated assembly, the projection is completely supported by the common wall, the projection is protected by 1-hour construction or fire retardant-treated wood, and the projection is limited to 18 inches (457 mm). These projections shall not contain any plumbing, electrical or mechanical installations. An easement may be required by the jurisdiction to ensure future access to this projection for repair and maintenance.

*Modification adds to modified language in IRC 2021-06.

Proponent: BOASC

Previous Code Cycles	Previous Modification Index Number	Previous Code Section
N/A		



South Carolina Department of Labor, Licensing and Regulation
South Carolina Building Codes Council
2021 Modification Index

Applicable Code: 2021 International Residential Code

Modification Index Number: IRC 2021-09

Code Section: R302.4.1 Through penetrations

Modification:

R302.4.1 Through penetrations. Through penetrations of fire-resistance-rated wall or floor assemblies shall comply with Section R302.4.1.1 or R302.4.1.2. No penetrations shall pass completely through the fire-rated assembly separating townhouse units.

Exceptions:

1. Where the penetrating items are steel, ferrous or copper pipes, tubes or conduits, the annular space shall be protected as follows:
 - 1.1. In concrete or masonry wall or floor assemblies, concrete, grout or mortar shall be permitted where installed to the full thickness of the wall or floor assembly or the thickness required to maintain the fire-resistance rating, provided that both of the following are complied with:
 - 1.1.1. The nominal diameter of the penetrating item is not more than 6 inches (152 mm).
 - 1.1.2. The area of the opening through the wall does not exceed 144 square inches (92 900 mm²).
 - 1.2. The material used to fill the annular space shall prevent the passage of flame and hot gases sufficient to ignite cotton waste where subjected to ASTM E119 or UL 263 time temperature fire conditions under a positive pressure differential of not less than 0.01 inch of water (3 Pa) at the location of the penetration for the time period equivalent to the fire-resistance rating of the construction penetrated.
2. The annular space created by the penetration of water-filled fire sprinkler piping, provided that the annular space is filled using a material complying with Item 1.2 of Exception 1.

Proponent: BOASC

Previous Code Cycles	Previous Modification Index Number	Previous Code Section
N/A		



South Carolina Department of Labor, Licensing and Regulation
South Carolina Building Codes Council
2021 Modification Index

Applicable Code: 2021 International Residential Code

Modification Index Number: IRC 2021-10

Code Section: R302.5.1 Opening protection

Modification:

R302.5.1 Opening protection. Openings from a private garage directly into a room used for sleeping purposes shall not be permitted. Other openings between the garage and residence shall be equipped with solid wood doors not less than 1³/₈ inches (35 mm) in thickness, solid or honeycomb-core steel doors not less than 1³/₈ inches (35 mm) thick, or 20-minute fire-rated doors. ~~Doors shall be self-latching and equipped with a self-closing or automatic-closing device.~~

Proponent: Home Builders Association of South Carolina

Previous Code Cycles	Previous Modification Index Number	Previous Code Section
IRC 2018	IRC 2018 05	R302.5.1
IRC 2015	IRC 2015 05	R302.5.1



South Carolina Department of Labor, Licensing and Regulation
South Carolina Building Codes Council
2021 Modification Index

Applicable Code: 2021 International Residential Code

Modification Index Number: IRC 2021-11

Code Section: R302.13 Fire protection of floors

Modification:

R302.13 Fire protection of floors. Floor assemblies that are not required elsewhere in this code to be fire-resistance rated, shall be provided with a 1/2-inch (12.7 mm) gypsum wallboard membrane, 5/8-inch (16 mm) *wood structural panel* membrane, or equivalent on the underside of the floor framing member. Penetrations or openings for ducts, vents, electrical outlets, lighting, devices, luminaires, wires, speakers, drainage, piping and similar openings or penetrations shall be permitted.

Exceptions:

1. Floor assemblies located directly over a space protected by an automatic sprinkler system in accordance with Section P2904, NFPA 13D, or other *approved* equivalent sprinkler system.
2. ~~Floor assemblies located directly over a crawl space not intended for storage or for the installation of fuel-fired or electric-powered heating appliances.~~ Floor assemblies located directly over a crawl space.
3. Portions of floor assemblies shall be permitted to be unprotected where complying with the following:
 - 3.1. The aggregate area of the unprotected portions does not exceed 80 square feet (7.4 m²) per story.
 - 3.2. Fireblocking in accordance with Section R302.11.1 is installed along the perimeter of the unprotected portion to separate the unprotected portion from the remainder of the floor assembly.
4. Wood floor assemblies using dimension lumber or *structural composite lumber* equal to or greater than 2-inch by 10-inch (50.8 mm by 254 mm) nominal dimension, or other *approved* floor assemblies demonstrating equivalent fire performance.

Proponent: Home Builders Association of South Carolina

Previous Code Cycles	Previous Modification Index Number	Previous Code Section
IRC 2018	IRC 2018 06	R302.13
IRC 2015	IRC 2015 06	R302.13



South Carolina Department of Labor, Licensing and Regulation
South Carolina Building Codes Council
2021 Modification Index

Applicable Code: 2021 International Residential Code

Modification Index Number: IRC 2021-12

Code Section: R303.4 Mechanical ventilation

Modification:

R303.4 Mechanical ventilation. Buildings and *dwelling units* complying with Section N1102.4.1 shall be provided with mechanical ventilation in accordance with Section M1505, or with other *approved* means of ventilation.

(Section deleted without substitution)

Proponent: Coastal Code Enforcement Association of SC

Previous Code Cycles	Previous Modification Index Number	Previous Code Section
IRC 2018	IRC 2018 07	R303.4
IRC 2015	IRC 2015 07	R303.4
IRC 2012	IRC 2012 05	R303.4



South Carolina Department of Labor, Licensing and Regulation
South Carolina Building Codes Council
2021 Modification Index

Applicable Code: 2021 International Residential Code

Modification Index Number: IRC 2021-13

Code Section: Figure R307.1 Minimum Fixture Clearances

Modification:

Change the minimum dimension for the side clearance between bathtub and water closet or bidet from 15 inches to 12 inches. See Figure on next page.

Proponent: Home Builders Association of South Carolina

Previous Code Cycles	Previous Modification Index Number	Previous Code Section
IRC 2018	IRC 2018 08	Figure R307.1
IRC 2015	IRC 2015 08	Figure R307.1
IRC 2012	IRC 2012 06	Figure R307.1
IRC 2006	IRC 2006 09	Figure R307.1
IRC 2003	IRC 2003 05	Figure R307.2

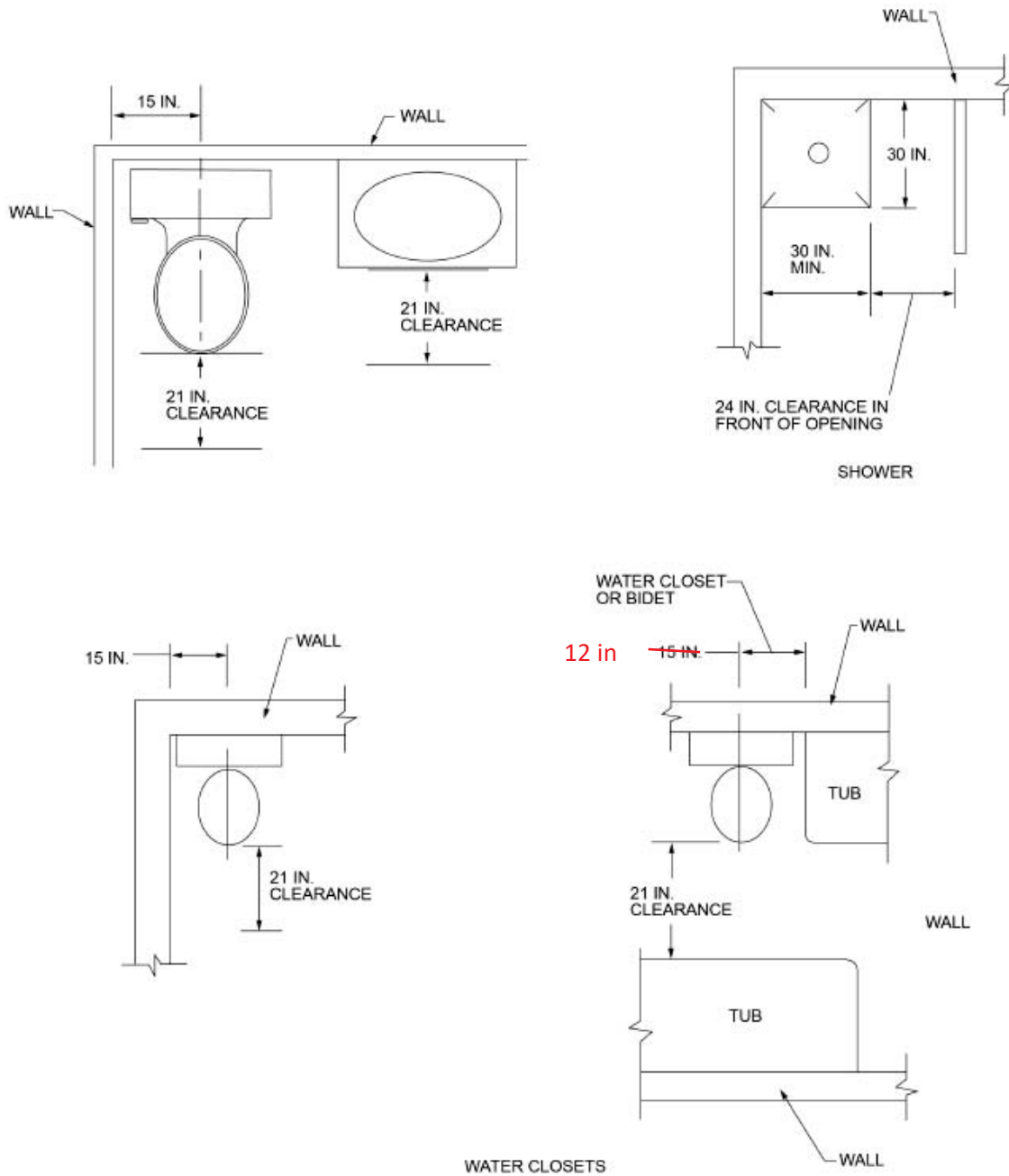

For SI: 1 inch = 25.4 mm.

FIGURE R307.1
MINIMUM FIXTURE CLEARANCES



South Carolina Department of Labor, Licensing and Regulation
South Carolina Building Codes Council
2021 Modification Index

Applicable Code: 2021 International Residential Code

Modification Index Number: IRC 2021-15

Code Section: R311.7.5.1 Risers

Modification:

R311.7.5.1 Risers. The maximum riser height shall be ~~not more than 7¾ inches (196 mm).~~ The maximum riser height for masonry stairs shall be 8 inches (203 mm). The *riser* height shall be measured vertically between leading edges of the adjacent treads. The greatest *riser* height within any flight of stairs shall not exceed the smallest by more than ³/₈ inch (9.5 mm). *Risers* shall be vertical or sloped from the underside of the *nosing* of the tread above at an angle not more than 30 degrees (0.51 rad) from the vertical. At open *risers*, openings located more than 30 inches (762 mm), as measured vertically, to the floor or *grade* below shall not permit the passage of a 4-inch-diameter (102 mm) sphere.

Exceptions:

1. The opening between adjacent treads is not limited on *spiral stairways*.
2. The *riser* height of *spiral stairways* shall be in accordance with Section 311.7.10.1.
3. The opening between adjacent treads is not limited on stairs with a total rise of 30 inches (762 mm) or less.

*The language above has been updated as of 9-9-2022 and the scrivener's errors in the exceptions have been corrected.

Proponent: Structural Engineers Association of South Carolina

Previous Code Cycles	Previous Modification Index Number	Previous Code Section
IRC 2018	IRC 2018 09	R311.7.5.1
IRC 2015	IRC 2015 09	R311.7.5.1
IRC 2012	IRC 2012 07	R311.7.5.1



South Carolina Department of Labor, Licensing and Regulation
South Carolina Building Codes Council
2021 Modification Index

Applicable Code: 2021 International Residential Code

Modification Index Number: IRC 2021-16

Code Section: R312.1.1 Where required

Modification:

R312.1.1 Where required. *Guards* shall be provided for those portions of open-sided walking surfaces, including floors, stairs, ramps and landings that are located more than 30 inches (762 mm) measured vertically to the floor or grade below at any point within 36 inches (914 mm) horizontally to the edge of the open side. Insect screening shall not be considered as a *guard*.

Guards shall be located along open-sided walking surfaces of all decks, porches, balconies, floors, stairs, ramps and landings that are located more than 30 inches (762 mm) measured vertically to the floor or grade below and at any point where a downward slope exceeds 3V:12H within 36 inches (914 mm) horizontally to the edge of the open side. Insect screening shall not be considered as a *guard*.

Proponent: Home Builders Association of South Carolina

Previous Code Cycles	Previous Modification Index Number	Previous Code Section
IRC 2018	IRC 2018 10	R312.1.1
IRC 2015	IRC 2015 10	R312.1.1
IRC 2012	IRC 2012 08	R312.1.1



South Carolina Department of Labor, Licensing and Regulation
South Carolina Building Codes Council
2021 Modification Index

Applicable Code: 2021 International Residential Code

Modification Index Number: IRC 2021-17

Code Section: R312.2 Window fall protection

Modification:

R312.2 Window fall protection. Window fall protection shall be provided in accordance with Sections R312.2.1 and R312.2.2

Deleted without substitution.

Proponent: Home Builders Association of South Carolina

Previous Code Cycles	Previous Modification Index Number	Previous Code Section
IRC 2018	IRC 2018 11	R312.2
IRC 2015	IRC 2015 11	R312.2
IRC 2012	IRC 2012 09	R312.2



South Carolina Department of Labor, Licensing and Regulation
South Carolina Building Codes Council
2021 Modification Index

Applicable Code: 2021 International Residential Code

Modification Index Number: IRC 2021-18

Code Section: R313 Automatic Fire Sprinkler Systems

Modification:

SECTION R313

AUTOMATIC FIRE SPRINKLER SYSTEMS

R313.1 Townhouse automatic fire sprinkler systems. An automatic residential fire sprinkler system shall not be required to be installed in townhouses when constructed in accordance with Section R302.2.

Exception: An automatic residential fire sprinkler system shall not be required where additions or alterations are made to existing townhouses that do not have an automatic residential fire sprinkler system installed.

R313.1.1 Design and installation. Automatic residential fire sprinkler systems for townhouses when installed shall be designed and installed in accordance with Section P2904 or NFPA 13D.

R313.2 One- and two-family dwellings automatic sprinkler systems. An automatic residential fire sprinkler system shall be installed shall not be required to be installed in one- and two-family dwellings.

Exception: An automatic residential fire sprinkler system shall not be required for additions or alterations to existing buildings that are not already provided with an automatic residential fire sprinkler system.

R313.2.1 Design and installation. Automatic residential fire sprinkler systems when installed shall be designed and installed in accordance with Section P2904 or NFPA 13D.

Proponent: Home Builders Association of South Carolina

Previous Code Cycles	Previous Modification Index Number	Previous Code Section
IRC 2018	IRC 2018 12	R313
IRC 2015	IRC 2015 12	R313
IRC 2012	IRC 2012 10	R313.1
IRC 2012	IRC 2012 11	R313.2



South Carolina Department of Labor, Licensing and Regulation
South Carolina Building Codes Council
2021 Modification Index

Applicable Code: 2021 International Residential Code

Modification Index Number: IRC 2021-22

Code Section: R317.1.1 Field treatment

Modification:

R317.1.1 Field treatment. Field-cut ends, notches and drilled holes of preservative-treated wood shall be treated in the field in accordance with AWP A M4 or in accordance with the preservative-treated wood product manufacturer's recommendations.

Proponent: Structural Engineers Association of South Carolina

Previous Code Cycles	Previous Modification Index Number	Previous Code Section
IRC 2018	IRC 2018 14	R317.1.1
IRC 2015	IRC 2015 13	R317.1.1
IRC 2012	IRC 2012 12	R317.1.1



South Carolina Department of Labor, Licensing and Regulation
South Carolina Building Codes Council
2021 Modification Index

Applicable Code: 2021 International Residential Code

Modification Index Number: IRC 2021-23

Code Section: R318.1 Subterranean termite control methods

Modification:

R318.1 Subterranean termite control methods. In areas subject to damage from termites as indicated by Table R301.2, protection shall be by one, or a combination, of the following methods:

1. Chemical termiticide treatment in accordance with Section R318.2.
2. Termite-baiting system installed and maintained in accordance with the *label*.
3. Pressure-preservative-treated wood in accordance with the provisions of Section R317.1.
4. Naturally durable termite-resistant wood.
5. Physical barriers in accordance with Section R318.3 and used in locations as specified in Section R317.1.
6. Cold-formed steel framing in accordance with Sections R505.2.1 and R603.2.1.
7. Treatments may be conducted as outlined in Section 27-1085 of the Rules and Regulations for the Enforcement of the South Carolina Pesticide Control Act and enforced by the Clemson University Department of Pesticide Regulation.

Proponent: Home Builders Association of SC

Previous Code Cycles	Previous Modification Index Number	Previous Code Section
IRC 2018	IRC 2018 15	R318.1



South Carolina Department of Labor, Licensing and Regulation
South Carolina Building Codes Council
2021 Modification Index

Applicable Code: 2021 International Residential Code

Modification Index Number: IRC 2021-24

Code Section: R318.4 Foam plastic protection

Modification:

R318.4 Foam plastic protection. In areas where the probability of termite infestation is “very heavy” as indicated in Figure R318.4, extruded and expanded polystyrene, polyisocyanurate and other foam plastics shall not be installed on the exterior face or under interior or exterior foundation walls or slab foundations located below *grade*. The clearance between foam plastics installed above *grade* and exposed earth shall be not less than 6 inches (152 mm). For crawl space applications, foam plastic shall be installed so as to provide a termite inspection gap of no less than 6 inches (152 mm) along the top of the foundation wall and foundation sill plate.

Exceptions:

1. Buildings where the structural members of walls, floors, ceilings and roofs are entirely of *noncombustible materials* or pressure-preservative-treated wood.
2. Where in addition to the requirements of Section R318.1, an *approved* method of protecting the foam plastic and structure from subterranean termite damage is used.
- ~~3-2.~~ On the interior side of basement *walls*.

Proponent: Home Builders Association of South Carolina

Previous Code Cycles	Previous Modification Index Number	Previous Code Section
IRC 2018	IRC 2018 16	R318.4



South Carolina Department of Labor, Licensing and Regulation
South Carolina Building Codes Council
2021 Modification Index

Applicable Code: 2021 International Residential Code

Modification Index Number: IRC 2021-25

Code Section: R318.5 Termite Inspection Strip

Modification:

R318.5 Termite inspection strip. Where foam plastic is applied in accordance with Section R318.4, a continuous 6-inch (152 mm) strip centered along the sill plate shall be left open for termite activity inspection.

Proponent: Home Builders Association of South Carolina

Previous Code Cycles	Previous Modification Index Number	Previous Code Section
N/A		



South Carolina Department of Labor, Licensing and Regulation
South Carolina Building Codes Council
2021 Modification Index

Applicable Code: 2021 International Residential Code

Modification Index Number: IRC 2021-28

Code Section: R322.1 General

Modification:

R322.1 General. Buildings and structures constructed in whole or in part in flood hazard areas, including A or V Zones and Coastal A Zones, as established in Table R301.2, and substantial improvement and *repair* of substantial damage of buildings and structures in flood hazard areas, shall be designed and constructed in accordance with the provisions contained in this section. Buildings and structures that are located in more than one flood hazard area shall comply with the provisions associated with the most restrictive flood hazard area. Buildings and structures located in whole or in part in identified floodways shall be designed and constructed in accordance with ASCE 24. Where there is a conflict with this code section and a locally adopted flood ordinance, the more restrictive provision shall apply.

Proponent: BOASC

Previous Code Cycles	Previous Modification Index Number	Previous Code Section
IRC 2018	IRC 2018 18	R322.1



South Carolina Department of Labor, Licensing and Regulation
South Carolina Building Codes Council
2021 Modification Index

Applicable Code: 2021 International Residential Code

Modification Index Number: IRC 2021-29

Code Section: R326.3 Story above grade plane

Modification:

R326.3 Story above grade plane. A habitable attic shall be considered a story above *grade plane*.

Exceptions: A habitable attic shall not be considered to be a story above *grade plane* provided that the habitable attic meets all the following:

1. The aggregate area of the habitable attic is either of the following:
 - 1.1. Not greater than ~~one-third~~ three-fourths of the floor area of the story below.
 - 1.2. Not greater than ~~one-half~~ of the floor area of the story below where the habitable attic is located within a dwelling unit equipped with a fire sprinkler system in accordance with Section P2904.
2. The occupiable space is enclosed by the roof assembly above, knee walls, if applicable, on the sides and the floor-ceiling assembly below.
3. The floor of the habitable attic does not extend beyond the exterior walls of the story below.
4. Where a habitable attic is located above a third story, the dwelling unit or townhouse unit shall be equipped with a fire sprinkler system in accordance with Section P2904.

Proponent: Home Builders Association of South Carolina

Previous Code Cycles	Previous Modification Index Number	Previous Code Section
N/A		



South Carolina Department of Labor, Licensing and Regulation
South Carolina Building Codes Council
2021 Modification Index

Applicable Code: 2021 International Residential Code

Modification Index Number: IRC 2021-31

Code Section: R404.1.9.2 Masonry piers supporting floor girders

Modification:

R404.1.9.2 Masonry piers supporting floor girders. Masonry piers supporting wood girders sized in accordance with Tables R602.7(1) and R602.7(2) shall be permitted in accordance with this section. Piers supporting girders for interior bearing walls shall have a minimum nominal dimension of 12 inches (305 mm) and a maximum height of 10 feet (3048 mm) be filled solidly with grout or type M or S mortar and shall have a minimum nominal dimension of 8 inches (203 mm) and a maximum height not exceeding 10 times the nominal thickness from top of footing to bottom of sill plate or girder. Piers supporting girders for exterior bearing walls shall have a minimum nominal dimension of 12 inches (305 mm) and a maximum height of 4 feet (1220 mm) from top of footing to bottom of sill plate or girder. Piers supporting beams and girders for exterior bearing walls shall be filled solidly with grout or type M or S mortar, shall contain a minimum of one #4 (13 mm) dowel mid-depth, and shall have a minimum nominal dimension of 8 inches (203 mm) and a maximum height of 4 times the nominal thickness from top of footing to bottom of sill plate or girder unless it can be shown by accepted engineering practice that there is sufficient foundation wall along the foundation line to resist the imposed lateral loads, in which case the maximum height shall not exceed 10 times the nominal thickness. Girders and sill plates shall be anchored to the pier or footing in accordance with Section R403.1.6 or Figure R404.1.5.3. Floor girder bearing shall be in accordance with Section R502.6.

Proponent: HBA of SC & Structural Engineers Association of SC

Previous Code Cycles	Previous Modification Index Number	Previous Code Section
IRC 2018	IRC 2018 20	R404.1.9.2
IRC 2015	IRC 2015 16	R404.1.9.2
IRC 2012	IRC 2012 13	R404.1.9.2



South Carolina Department of Labor, Licensing and Regulation
South Carolina Building Codes Council
2021 Modification Index

Applicable Code: 2021 International Residential Code

Modification Index Number: IRC 2021-32

Code Section: R408.3 Unvented crawl space

Modification:

R408.3 Unvented crawl space. For unvented under-floor spaces, the following items shall be provided:

1. Exposed earth shall be covered with a continuous ~~Class I~~ vapor retarder meeting ASTM E1745 Class A. Joints of the vapor retarder shall overlap by 6 inches (152 mm) and shall be sealed or taped. The edges of the vapor retarder shall extend not less than 6 inches (152 mm) up the stem wall and shall be attached and sealed to the stem wall or insulation.
2. One of the following shall be provided for the under-floor space:
 - 2.1. Continuously operated mechanical exhaust ventilation at a rate equal to 1 cubic foot per minute (0.47 L/s) for each 50 square feet (4.7m²) of *crawl space* floor area, including an air pathway to the common area (such as a duct or transfer grille), and perimeter walls insulated in accordance with Section N1102.2.10.1 of this code.
 - 2.2. *Conditioned air* supply sized to deliver at a rate equal to 1 cubic foot per minute (0.47 L/s) for each 50 square feet (4.7 m²) of under-floor area, including a return air pathway to the common area (such as a duct or transfer grille), and perimeter walls insulated in accordance with Section N1102.2.10.1 of this code.
 - 2.3. Plenum in existing structures complying with Section M1601.5, if under-floor space is used as a plenum.
 - 2.4. Dehumidification sized in accordance with manufacturer's specifications.

Proponent: Structural Engineers Association of South Carolina

Previous Code Cycles	Previous Modification Index Number	Previous Code Section
IRC 2018	IRC 2018 21	R408.3



South Carolina Department of Labor, Licensing and Regulation
South Carolina Building Codes Council
2021 Modification Index

Applicable Code: 2021 International Residential Code

Modification Index Number: IRC 2021-33

Code Section: R408.3(2.2) Unvented crawl space

Modification:

R408.3 Unvented crawl space. For unvented under-floor spaces, the following items shall be provided:

1. Exposed earth shall be covered with a continuous vapor retarder meeting ASME E1745 Class A. Joints of the vapor retarder shall overlap by 6 inches (152 mm) and shall be sealed or taped. The edges of the vapor retarder shall extend not less than 6 inches (152 mm) up the stem wall and shall be attached and sealed to the stem wall or insulation.
2. One of the following shall be provided for the underfloor space:
 - 2.1. Continuously operated mechanical exhaust ventilation at a rate equal to 1 cubic foot per minute (0.47 L/s) for each 50 square feet (4.7m²) of *crawl space* floor area, including an air pathway to the common area (such as a duct or transfer grille), and perimeter walls insulated in accordance with Section N1102.2.10.1 of this code.
 - 2.2. *Conditioned air* supply sized to deliver at a rate equal to 1 cubic foot per minute (0.47 L/s) for each 50 square feet (4.7 m²) of underfloor area, including a return air pathway to the common area (such as a duct or transfer grille), and perimeter walls insulated in accordance with ~~Section N1102.2.10.1 of this code~~ the South Carolina Energy Code.
 - 2.3. Plenum in existing structures complying with Section M1601.5, if under-floor space is used as a plenum.
 - 2.4. Dehumidification sized in accordance with manufacturer's specifications.

*Modification adds to modified language in IRC 2021-32.

Proponent: Home Builders Association of South Carolina

Previous Code Cycles	Previous Modification Index Number	Previous Code Section
N/A		



South Carolina Department of Labor, Licensing and Regulation
South Carolina Building Codes Council
2021 Modification Index

Applicable Code: 2021 International Residential Code

Modification Index Number: IRC 2021-34

Code Section: R408.4 Access

Modification:

R408.4 Access. Access shall be provided to all under-floor spaces. Access openings through the floor shall be not smaller than 18 inches by 24 inches (457 mm by 610 mm). Openings through a perimeter wall shall be not less than 16 inches by 24 inches (407 mm by 610 mm). Where any portion of the through-wall access is below *grade*, an areaway not less than 16 inches by 24 inches (407 mm by 610 mm) shall be provided. The bottom of the areaway shall be below the threshold of the access opening. ~~Through wall access openings shall not be located under a door to the residence.~~ See Section M1305.1.3 for access requirements where mechanical *equipment* is located under floors.

Proponent: Home Builders Association of South Carolina

Previous Code Cycles	Previous Modification Index Number	Previous Code Section
IRC 2018	IRC 2018 22	R408.4
IRC 2015	IRC 2015 17	R408.4



South Carolina Department of Labor, Licensing and Regulation
South Carolina Building Codes Council
2021 Modification Index

Applicable Code: 2021 International Residential Code

Modification Index Number: IRC 2021-35

Code Section: R408.8 Under-floor vapor retarder

Modification:

R408.8 Under-floor vapor retarder. In Climate Zones 1A, 2A and 3A below the warm-humid line, a continuous Class I or II vapor retarder shall be provided on the exposed face of air-permeable insulation installed between the floor joists and exposed to the grade in the under-floor space. The vapor retarder shall have a maximum water vapor permeance of 1.5 perms when tested in accordance with Procedure B of ASTM E96.

Exception: The vapor retarder shall not be required in unvented *crawl spaces* constructed in accordance with Section R408.3.

Deleted without substitution.

Proponent: Home Builders Association of South Carolina

Previous Code Cycles	Previous Modification Index Number	Previous Code Section
N/A		



South Carolina Department of Labor, Licensing and Regulation
South Carolina Building Codes Council
2021 Modification Index

Applicable Code: 2021 International Residential Code

Modification Index Number: IRC 2021-36

Code Section: R502.11.4 Truss design drawings

Modification:

R502.11.4 Truss design drawings. *Truss design drawings*, prepared in compliance with Section R502.11.1, shall be submitted to the *building official* ~~and approved prior to installation at the time of their inspection.~~ *Truss design drawings* shall be provided with the shipment of trusses delivered to the job site. *Truss design drawings* shall include, at a minimum, the information specified as follows:

1. Slope or depth, span and spacing.
2. Location of all joints.
3. Required bearing widths.
4. Design loads as applicable:
 - 4.1. Top chord *live load*.
 - 4.2. Top chord dead load.
 - 4.3. Bottom chord *live load*.
 - 4.4. Bottom chord dead load.
 - 4.5. Concentrated loads and their points of application.
 - 4.6. Controlling wind and earthquake loads.
5. Adjustments to lumber and joint connector design values for conditions of use.
6. Each reaction force and direction.
7. Joint connector type and description, such as size, thickness or gage, and the dimensioned location of each joint connector except where symmetrically located relative to the joint interface.
8. Lumber size, species and grade for each member.
9. Connection requirements for:
 - 9.1. Truss-to-girder-truss.
 - 9.2. Truss ply-to-ply.
 - 9.3. Field splices.
10. Calculated deflection ratio, maximum description for live and total load, or both.
11. Maximum axial compression forces in the truss members to enable the building designer to design the size, connections and anchorage of the permanent continuous lateral bracing. Forces shall be shown on the truss drawing or on supplemental documents.
12. Required permanent truss member bracing location.

Proponent: Home Builders Association of South Carolina

Previous Code Cycles	Previous Modification Index Number	Previous Code Section
IRC 2018	IRC 2018 23	R502.11.4
IRC 2015	IRC 2015 18	R502.11.4
IRC 2012	IRC 2012 14	R502.11.4
IRC 2006	IRC 2006 21	R502.11.4
IRC 2003	IRC 2003 17	R502.11.4



South Carolina Department of Labor, Licensing and Regulation
South Carolina Building Codes Council
2021 Modification Index

Applicable Code: 2021 International Residential Code

Modification Index Number: IRC 2021-37

Code Section: R506.2.3 Vapor retarder

Modification:

R506.2.3 Vapor retarder. A minimum 10-mil (0.010 inch; 0.254 mm) vapor retarder conforming to ASTM E1745 Class A requirements with joints lapped not less than 6 inches (152 mm) shall be placed between the concrete floor slab and the base course or the prepared subgrade where a base course does not exist.

Exception: The vapor retarder is not required for the following:

1. ~~Garages~~, utility buildings and other unheated *accessory structures*.
2. For unheated storage rooms having an area of less than 70 square feet (6.5 m²) and carports.
3. Driveways, walks, patios and other flatwork not likely to be enclosed and heated at a later date.
4. Where *approved* by the *building official*, based on local site conditions.

Proponent: Structural Engineers Association of South Carolina

Previous Code Cycles	Previous Modification Index Number	Previous Code Section
IRC 2018	IRC 2018 24	R506.2.3
IRC 2015	IRC 2015 19	R506.2.3



South Carolina Department of Labor, Licensing and Regulation
South Carolina Building Codes Council
2021 Modification Index

Applicable Code: 2021 International Residential Code

Modification Index Number: IRC 2021-38

Code Section: R606.7 Piers

Modification:

R606.7 Piers. The unsupported height of masonry piers shall not exceed 10 times their least dimension. Where structural clay tile or hollow *concrete masonry units* are used for isolated piers to support beams and girders, the cellular spaces shall be filled solidly with grout or Type M or S mortar, except that unfilled hollow piers shall be permitted to be used if their unsupported height is not more than four times their least dimension. Where *hollow masonry units* are solidly filled with grout or Type M or S ~~or N~~ mortar, the allowable compressive stress shall be permitted to be increased as provided in Table R606.9.

Proponent: Structural Engineers Association of South Carolina

Previous Code Cycles	Previous Modification Index Number	Previous Code Section
IRC 2018	IRC 2018 25	R606.7
IRC 2015	IRC 2015 20	R606.7



South Carolina Department of Labor, Licensing and Regulation
South Carolina Building Codes Council
2021 Modification Index

Applicable Code: 2021 International Residential Code

Modification Index Number: IRC 2021-39

Code Section: R802.10.1 Truss design drawings

Modification:

R802.10.1 Truss design drawings. *Truss design drawings*, prepared in conformance to Section R802.10.1, shall be provided to the *building official* and ~~approved prior to installation~~ at the time of their inspection. *Truss design drawings* shall be provided with the shipment of trusses delivered to the job site. *Truss design drawings* shall include, at a minimum, the following information:
 (items 1-12 unchanged)

Proponent: Home Builders Association of South Carolina

Previous Code Cycles	Previous Modification Index Number	Previous Code Section
IRC 2018	IRC 2018 26	R802.10.1
IRC 2015	IRC 2015 21	R802.10.1



South Carolina Department of Labor, Licensing and Regulation
South Carolina Building Codes Council
2021 Modification Index

Applicable Code: 2021 International Residential Code

Modification Index Number: IRC 2021-40

Code Section: R905.2.8.5 Drip edge

Modification:

R905.2.8.5 Drip edge. A drip edge shall be provided at eaves and rake edges of shingle roofs. Adjacent segments of drip edge shall be overlapped not less than 2 inches (51 mm). Drip edges shall extend not less than 1/4 inch (6.4 mm) below the roof sheathing and extend up back onto the *roof deck* not less than 2 inches (51 mm). Drip edges shall be mechanically fastened to the *roof deck* at not more than 12 inches (305 mm) o.c. with fasteners as specified in Section R905.2.5. *Underlayment* shall be installed over the drip edge along eaves and under the drip edge along rake edges. A drip edge shall be provided at eaves and rake edges of asphalt shingle roofs where required by the manufacturer.

Proponent: Home Builders Association of South Carolina

Previous Code Cycles	Previous Modification Index Number	Previous Code Section
IRC 2018	IRC 2018 27	R905.2.8.5
IRC 2015	IRC 2015 22	R905.2.8.5



South Carolina Department of Labor, Licensing and Regulation
South Carolina Building Codes Council
2021 Modification Index

Applicable Code: 2021 International Residential Code

Modification Index Number: IRC 2021-41

Code Section: Chapter 11 Energy Efficiency

Modification:

**CHAPTER 11 [RE]
ENERGY EFFICIENCY**

Chapter deleted without substitution. The State of South Carolina has specific energy standards in statutory form (Re: Title 6, Chapter 9, Building Codes and Title 6, Chapter 10, Building Energy Efficiency Standard Act). To eliminate any possible conflicts concerning the insulation requirements for single and two family residential buildings between the International Residential Code and state law, Chapter 11 was deleted.*

*All references to Chapter 11 in the Referenced Standards chapter and Index have been removed.

Proponent: Home Builders Association of South Carolina

Previous Code Cycles	Previous Modification Index Number	Previous Code Section
IRC 2018	IRC 2018 28	Chapter 11
IRC 2015	IRC 2015 22	Chapter 11
IRC 2012	IRC 2012 16	Chapter 11
IRC 2006	IRC 2006 27	Chapter 11
IRC 2003	IRC 2003 21	Chapter 11



South Carolina Department of Labor, Licensing and Regulation
South Carolina Building Codes Council
2021 Modification Index

Applicable Code: 2021 International Residential Code

Modification Index Number: IRC 2021-42

Code Section: M1411.6 Insulation and refrigerant piping

Modification:

M1411.6 Insulation of refrigerant piping. Piping and fittings for refrigerant vapor (suction) lines shall be insulated with insulation having a thermal resistivity of ~~not less than R-3~~ at least R 2.5 hr. ft 2 F/Btu and having external surface permeance not exceeding 0.05 perm [2.87 ng/(s × m² × Pa)] when tested in accordance with ASTM E96.

Proponent: Home Builders Association of South Carolina

Previous Code Cycles	Previous Modification Index Number	Previous Code Section
IRC 2018	IRC 2018 29	M1411.6
IRC 2015	IRC 2015 24	M1411.6
IRC 2012	IRC 2012 18	M1411.6
IRC 2006	IRC 2006 28	M1411.5
IRC 2003	IRC 2003 22	M1411.4



South Carolina Department of Labor, Licensing and Regulation
South Carolina Building Codes Council
2021 Modification Index

Applicable Code: 2021 International Residential Code

Modification Index Number: IRC 2021-43

Code Section: M1411.9 Locking access port caps

Modification:

M1411.9 Locking access port caps. Refrigerant circuit access ports located outdoors shall be fitted with locking type tamper-resistant caps or shall be otherwise secured to prevent unauthorized access.

Deleted without substitution.

Proponent: Home Builders Association of South Carolina

Previous Code Cycles	Previous Modification Index Number	Previous Code Section
IRC 2018	IRC 2018 30	M1411.8
IRC 2015	IRC 2015 25	M1411.6
IRC 2012	IRC 2012 18	M1411.6



South Carolina Department of Labor, Licensing and Regulation
South Carolina Building Codes Council
2021 Modification Index

Applicable Code: 2021 International Residential Code

Modification Index Number: IRC 2021-44

Code Section: M1502.3 Duct termination

Modification:

M1502.3 Duct termination. Exhaust ducts shall terminate on the outside of the building. Exhaust duct terminations shall be in accordance with the dryer manufacturer's installation instructions. If the manufacturer's instructions do not specify a termination location, the exhaust duct shall terminate not less than 3 feet (914 mm) in any direction from openings into buildings, including openings in ventilated soffits. Exhaust duct terminations shall be equipped with a backdraft damper. Screens shall not be installed at the duct termination.

Proponent: Home Builders Association of South Carolina

Previous Code Cycles	Previous Modification Index Number	Previous Code Section
IRC 2018	IRC 2018 31	M1502.3
IRC 2015	IRC 2015 26	M1502.3
IRC 2012	IRC 2012 19	M1502.3
IRC 2006	IRC 2006 29	M1502.2



South Carolina Department of Labor, Licensing and Regulation
South Carolina Building Codes Council
2021 Modification Index

Applicable Code: 2021 International Residential Code

Modification Index Number: IRC 2021-45

Code Section: M1502.4.2 Duct installation

Modification:

M1502.4.2 Duct installation. Exhaust ducts shall be supported at intervals not to exceed 8 feet (2438 mm) and within 16 inches (406 mm) of each side of a joint that is not installed in a vertical orientation, 12 feet (3658 mm) and shall be secured in place, making rigid contact with the duct at not less than 4 equally spaced points or two-thirds contact if strap is used. All brackets or strapping must be noncombustible. The insert end of the duct shall extend into the adjoining duct or fitting in the direction of airflow. The overlap shall comply with Section M1601.4.2. Ducts shall not be joined with screws or similar devices that protrude into the inside of the duct. Exhaust ducts joints shall be sealed in accordance with Section M1601.4.1. and shall be mechanically fastened. Ducts shall not be joined with screws or similar fasteners that protrude more than 1/8 inch (3.2 mm) into the inside of the duct. Where dryer exhaust ducts are enclosed in wall or ceiling cavities, such cavities shall allow the installation of the duct without deformation. The duct work may be ovalized as long as it terminates in an approved duct box. Minor imperfections located on the duct, in areas other than along the seam, do not constitute a violation.

Proponent: Home Builders Association of South Carolina

Previous Code Cycles	Previous Modification Index Number	Previous Code Section
IRC 2018	IRC 2018 32	M1502.4.2



South Carolina Department of Labor, Licensing and Regulation
South Carolina Building Codes Council
2021 Modification Index

Applicable Code: 2021 International Residential Code

Modification Index Number: IRC 2021-46

Code Section: M1502.4.6 Duct length

Modification:

M1502.4.6 Duct length. ~~The maximum allowable exhaust duct length shall be determined by one of the methods specified in Sections M1502.4.6.1 through M1502.4.6.3.~~ The maximum length of a clothes dryer exhaust duct shall not exceed 35 feet (10668 mm) from the dryer location to the wall or roof termination.

Proponent: Home Builders Association of South Carolina

Previous Code Cycles	Previous Modification Index Number	Previous Code Section
IRC 2018	IRC 2018 33	M1502.4.5
IRC 2015	IRC 2015 27	M1502.4.4
IRC 2012	IRC 2012 20	M1502.4.4
IRC 2006	IRC 2006 30	M1502.6



South Carolina Department of Labor, Licensing and Regulation
South Carolina Building Codes Council
2021 Modification Index

Applicable Code: 2021 International Residential Code

Modification Index Number: IRC 2021-47

Code Section: M1503.6 Makeup air

Modification:

~~M1503.6 Makeup air required. Where one or more gas, liquid or solid fuel-burning *appliance* that is neither directvent nor uses a mechanical draft venting system is located within a dwelling unit's air barrier, each exhaust system capable of exhausting in excess of 400 cubic feet per minute (0.19 m³/s) shall be mechanically or passively provided with makeup air at a rate approximately equal to the exhaust air rate. Such makeup air systems shall be equipped with not fewer than one damper complying with Section M1503.6.2.~~

~~**Exception:** Makeup air is not required for exhaust systems installed for the exclusive purpose of space cooling and intended to be operated only when windows or other air inlets are open.~~

Exhaust hood systems capable of exhausting more than 400 cubic feet per minute (0.1 9 m³ /s) shall be mechanically or naturally provided with makeup air at a rate approximately equal to the exhaust air rate more than 400 cubic feet (0.19 m³/s) per minute. Such makeup air systems shall be equipped with not less than one damper. Each damper shall be a gravity damper or an electrically operated damper that automatically opens when the exhaust system operates. Dampers shall be accessible for inspection, service, repair and replacement without removing permanent construction or any other ducts not connected to the damper being inspected, serviced, repaired or replaced.

Proponent: Home Builders Association of South Carolina

Previous Code Cycles	Previous Modification Index Number	Previous Code Section
IRC 2018	IRC 2018 34	M1503.6
IRC 2015	IRC 2015 28	M1503.4



South Carolina Department of Labor, Licensing and Regulation
South Carolina Building Codes Council
2021 Modification Index

Applicable Code: 2021 International Residential Code

Modification Index Number: IRC 2021-48

Code Section: M1504.3 Exhaust openings

Modification:

M1504.3 Exhaust openings. Air exhaust openings shall terminate as follows:

1. Not less than 3 feet (914 mm) from property lines.
2. Not less than 3 feet (914 mm) from gravity air intake openings, operable windows and doors.
3. Not less than 10 feet (3048 mm) from mechanical air intake openings except where the exhaust opening is located not less than 3 feet (914 mm) above the air intake opening. Openings shall comply with Sections R303.5.2 and R303.6.

Exception: Bathrooms, water closets and shower spaces.

Proponent: Home Builders Association of South Carolina

Previous Code Cycles	Previous Modification Index Number	Previous Code Section
IRC 2018	IRC 2018 35	M1504.3



South Carolina Department of Labor, Licensing and Regulation
South Carolina Building Codes Council
2021 Modification Index

Applicable Code: 2021 International Residential Code

Modification Index Number: IRC 2021-49

Code Section: M1601.4.1 Joints, Seams and Connections

Modification:

M1601.4.1 Joints, seams and connections. Longitudinal and transverse joints, seams and connections in metallic and nonmetallic ducts shall be constructed as specified in SMACNA *HVAC Duct Construction Standards --Metal and Flexible* and NAIMA *Fibrous Glass Duct Construction Standards*. Joints, longitudinal and transverse seams, and connections in ductwork shall be securely fastened and sealed with welds, gaskets, mastics (adhesives), mastic plus-embedded-fabric systems, liquid sealants or tapes. Tapes and mastics used to seal fibrous glass ductwork shall be *listed* and *labeled* in accordance with UL 181A and shall be marked “181A-P” for pressure sensitive tape, “181 A-M” for mastic or “181 A-H” for heat-sensitive tape.

Tapes and mastics used to seal metallic and flexible air ducts and flexible air connectors shall comply with UL 181B and shall be marked “181 B-FX” for pressure-sensitive tape or “181 BM” for mastic. Duct connections to flanges of air distribution system *equipment* shall be sealed and mechanically fastened. Mechanical fasteners for use with flexible nonmetallic air ducts shall comply with UL 181B and shall be marked 181B-C. Crimp joints for round metallic ducts shall have a contact lap of not less than 1 inch (25 mm) and shall be mechanically fastened by means of not less than three sheet-metal screws or rivets equally spaced around the joint. Closure systems used to seal all ductwork shall be installed in accordance with the manufacturers' instructions.

Exceptions:

1. Spray polyurethane foam shall be permitted to be applied without additional joint seals.
2. Where a duct connection is made that is partially without access, three screws or rivets shall be equally spaced on the exposed portion of the joint so as to prevent a hinge effect.
3. For ducts having a static pressure classification of less than 2 inches of water column (500 Pa), additional closure systems shall not be required for continuously welded joints and seams and locking-type joints and seams. ~~This exception shall not apply to snap-lock and button-lock type joints and seams that are located outside of conditioned spaces.~~

Proponent: Home Builders Association of South Carolina

Previous Code Cycles	Previous Modification Index Number	Previous Code Section
IRC 2018	IRC 2018 36	M1601.4.1
IRC 2015	IRC 2015 29	M1601.4.1



South Carolina Department of Labor, Licensing and Regulation
South Carolina Building Codes Council
2021 Modification Index

Applicable Code: 2021 International Residential Code

Modification Index Number: IRC 2021-50

Code Section: G2418.2 Design and installation

Modification:

G2418.2 (407.2) Design and installation. *Piping* shall be supported with ~~metal~~ pipe hooks, ~~metal~~ pipe straps, ~~metal~~ bands, ~~metal~~ brackets, ~~metal~~ hangers or building structural components suitable for the size of *piping*, of adequate strength and quality, and located at intervals so as to prevent or damp out excessive vibration. *Piping* shall be anchored to prevent undue strains on connected *appliances* and shall not be supported by other *piping*. Pipe hangers and supports shall conform to the requirements of MSS SP-58 and shall be spaced in accordance with Section G2424. Supports, hangers and anchors shall be installed so as not to interfere with the free expansion and contraction of the *piping* between anchors. The components of the supporting *equipment* shall be designed and installed so that they will not be disengaged by movement of the supported *piping*.

Proponent: Home Builders Association of South Carolina

Previous Code Cycles	Previous Modification Index Number	Previous Code Section
IRC 2018	IRC 2018 37	G2418.2
IRC 2015	IRC 2015 30	G2418.2
IRC 2012	IRC 2012 21	G2418.2



South Carolina Department of Labor, Licensing and Regulation
South Carolina Building Codes Council
2021 Modification Index

Applicable Code: 2021 International Residential Code

Modification Index Number: IRC 2021-51

Code Section: P2503.6 Shower liner test

Modification:

P2503.6 Shower liner test. Where shower floors and receptors are made watertight by the application of materials required by Section P2709.2, the completed liner installation shall be tested. ~~The pipe from the shower drain shall be plugged watertight for the test. The floor and receptor area shall be filled with potable water to a depth of not less than 2 inches (51 mm) measured at the threshold. Where a threshold of not less than 2 inches (51 mm) in height does not exist, a temporary threshold shall be constructed to retain the test water in the lined floor or receptor area to a level not less than 2 inches (51 mm) in depth measured at the threshold. The water shall be retained~~ The shower liner shall be tested to the lesser of the depth of threshold or 2 inches (51 mm) and shall be operated at normal pressure for a test period of not less than 15 minutes and there shall not be evidence of leakage.

Proponent: Home Builders Association of South Carolina

Previous Code Cycles	Previous Modification Index Number	Previous Code Section
IRC 2018	IRC 2018 38	P2503.6
IRC 2015	IRC 2015 31	P2503.6
IRC 2012	IRC 2012 22	P2503.6



South Carolina Department of Labor, Licensing and Regulation
South Carolina Building Codes Council
2021 Modification Index

Applicable Code: 2021 International Residential Code

Modification Index Number: IRC 2021-52

Code Section: P2503.6 Shower liner test

Modification:

P2503.6 Shower liner test. Where shower floors and receptors are made watertight by the application of materials required by Section P2709.2, the completed liner installation shall be tested. The shower liner shall be tested to the lesser of the depth of threshold or 2 inches (51 mm) and shall be operated at normal pressure for a test period of not less than 15 minutes and there shall not be evidence of leakage. The shower liner test shall be performed at the final plumbing inspection.

*Modification adds to modified language in IRC 2021-51.

Proponent: Home Builders Association of South Carolina

Previous Code Cycles	Previous Modification Index Number	Previous Code Section
N/A		



South Carolina Department of Labor, Licensing and Regulation
South Carolina Building Codes Council
2021 Modification Index

Applicable Code: 2021 International Residential Code

Modification Index Number: IRC 2021-53

Code Section: P2603.2.1 Protection against physical damage

Modification:

P2603.2.1 Protection against physical damage. In concealed locations, where piping, other than cast-iron or galvanized steel, is installed through holes or notches in studs, joists, rafters or similar members less than 1¼ inches (31.8 mm) from the nearest edge of the member, the pipe shall be protected by steel shield plates. Such shield plates shall have a thickness of not less than 0.0575 inch (1.463 mm) (No. 16 Gage). Such plates shall cover the area of the pipe where the member is notched or bored, and shall extend not less than 2 inches (51 mm) above sole plates and below top plates. Steel shield plates shall not be secured with nails or screws, unless required by the manufacturer.

Proponent: Home Builders Association of South Carolina

Previous Code Cycles	Previous Modification Index Number	Previous Code Section
N/A		



South Carolina Department of Labor, Licensing and Regulation
South Carolina Building Codes Council
2021 Modification Index

Applicable Code: 2021 International Residential Code

Modification Index Number: IRC 2021-54

Code Section: P2603.5 Freezing

Modification:

P2603.5 Freezing. In localities having a winter design temperature of 32°F (0°C) or lower as shown in Table R301.2 of this code, a water, soil or waste pipe shall not be installed outside of a building, in exterior walls, in *attics* or crawl spaces, or in any other place subjected to freezing temperature unless adequate provision is made to protect it from freezing by insulation or heat or both. Water service pipe shall be installed not less than 12 inches (305 mm) deep and not less than 6 inches (152 mm) below the frost line.

Proponent: Home Builders Association of South Carolina

Previous Code Cycles	Previous Modification Index Number	Previous Code Section
IRC 2018	IRC 2018 39	P2603.5
IRC 2015	IRC 2015 32	P2603.5



South Carolina Department of Labor, Licensing and Regulation
South Carolina Building Codes Council
2021 Modification Index

Applicable Code: 2021 International Residential Code

Modification Index Number: IRC 2021-55

Code Section: P2603.5 Freezing

Modification:

P2603.5 Freezing. In localities having a winter design temperature of 32°F (0°C) or lower as shown in Table R301.2 of this code, a water pipe shall not be installed outside of a building, in exterior walls, in *attics* or crawl spaces, or in any other place subjected to freezing temperature unless adequate provision is made to protect it from freezing by insulation or heat or both. Water service pipe shall be installed not less than 12 inches (305 mm) deep and not less than 6 inches (152 mm) below the frost line.
Exception: Water pipes that are installed on the warm in winter side of the building envelope, i.e., above the insulation line in a floor system or below the insulation line in an attic, do not need additional pipe insulation.

*Modification adds to modified language in IRC 2021-54.

Proponent: Home Builders Association of South Carolina

Previous Code Cycles	Previous Modification Index Number	Previous Code Section
n/a		



South Carolina Department of Labor, Licensing and Regulation
South Carolina Building Codes Council
2021 Modification Index

Applicable Code: 2021 International Residential Code

Modification Index Number: IRC 2021-56

Code Section: P2705.1(3) General

Modification:

P2705.1 General. The installation of fixtures shall conform to the following:

1. Floor-outlet or floor-mounted fixtures shall be secured to the drainage connection and to the floor, where so designed, by screws, bolts, washers, nuts and similar fasteners of copper, copper alloy or other corrosion-resistant material.
2. Wall-hung fixtures shall be rigidly supported so that strain is not transmitted to the plumbing system.
3. Where fixtures come in contact with walls and floors, the contact area shall be watertight.

Exception: Water closets and/or bidets shall not be required to be caulked to flooring surface.

4. Plumbing fixtures shall be usable.
5. Water closets, lavatories and bidets. A water closet, lavatory or bidet shall not be set closer than 15 inches (381 mm) from its center to any side wall, partition or vanity or closer than ~~30 inches (762 mm)~~ 27 inches center-to-center between adjacent fixtures. There shall be a clearance of not less than 21 inches (533 mm) in front of a water closet, lavatory or bidet to any wall, fixture or door.
6. The location of piping, fixtures or equipment shall not interfere with the operation of windows or doors.
7. In flood hazard areas as established by Table R301.2, plumbing fixtures shall be located or installed in accordance with Section R322.1.6.
8. Integral fixture-fitting mounting surfaces on manufactured plumbing fixtures or plumbing fixtures constructed on site, shall meet the design requirements of ASME A112.19.2/CSA B45.1 or ASME A112.19.3/CSA B45.4.

*Modification includes the approved portion of IRC 2021-14 in (5).

Proponent: Home Builders Association of South Carolina

Previous Code Cycles	Previous Modification Index Number	Previous Code Section
N/A		



South Carolina Department of Labor, Licensing and Regulation
South Carolina Building Codes Council
2021 Modification Index

Applicable Code: 2021 International Residential Code

Modification Index Number: IRC 2021-57

Code Section: P2708.4 Shower control valves

Modification:

P2708.4 Shower control valves. Individual shower and tub/shower combination valves shall be balanced-pressure, thermostatic or combination balanced-pressure/thermostatic valves that conform to the requirements of ASSE 1016/ASME 112.1016/CSA B125.16 or ASME A112.18.1/CSA B125.1. ~~Shower control valves shall be rated for the flow rate of the installed shower head. Such valves shall be installed at the point of use.~~ Shower and tub/shower combination valves required by this section shall be equipped with a means to limit the maximum setting of the valve to 120°F (49°C), which shall be field adjusted in accordance with the manufacturer's instructions to provide water at a temperature not to exceed 120°F (49°C). In-line thermostatic valves shall not be utilized for compliance with this section.

Proponent: Home Builders Association of South Carolina

Previous Code Cycles	Previous Modification Index Number	Previous Code Section
N/A		



South Carolina Department of Labor, Licensing and Regulation
South Carolina Building Codes Council
2021 Modification Index

Applicable Code: 2021 International Residential Code

Modification Index Number: IRC 2021-58

Code Section: P2713.3 Bathtub and whirlpool bathtub valves

Modification:

P2713.3 Bathtub and whirlpool bathtub valves. Bathtubs and whirlpool bathtub valves shall have or be supplied by a water-temperature-limiting device that conforms to ASSE 1070/ASME A112.1070/CSA B125.70, except where such valves are combination tub/shower valves in accordance with Section P2708.4. The water-temperature-limiting device required by this section shall be equipped with a means to limit the maximum setting of the device to 120°F (49°C), and, where adjustable, shall be field-adjusted in accordance with the manufacturer's instructions to provide hot water at a temperature not to exceed 120°F (49°C). Access shall be provided to water-temperature-limiting devices that conform to ASSE 1070/ASME A112.1070/CSA B125.70.

Exception: Access is not required for nonadjustable water-temperature-limiting devices that conform to ASSE 1070/ASME A112.1070/CSA B125.70 and are integral with a fixture fitting, provided that the fixture fitting itself can be accessed for replacement.

Hot water supplied to bathtubs and whirlpool bathtubs shall be limited to a temperature of not greater than 120°F (49°C) by a water-temperature limiting device that conforms to ASSE 1070/ASME A112.1070/CSA B125.70 or CSA B125.3, except where such protection is otherwise provided by a combination tub/shower valve in accordance with Section P2708.4.

Proponent: Home Builders Association of South Carolina

Previous Code Cycles	Previous Modification Index Number	Previous Code Section
N/A		



South Carolina Department of Labor, Licensing and Regulation
South Carolina Building Codes Council
2021 Modification Index

Applicable Code: 2021 International Residential Code

Modification Index Number: IRC 2021-60

Code Section: P2903.10 Hose bib

Modification:

P2903.10 Hose bib. Hose bibbs subject to freezing, including the “frostproof” type, shall be equipped with an accessible stop-and-waste-type valve inside the building so that they can be controlled and drained during cold periods.

Exception: Frostproof hose bibbs installed such that the stem extends through the building insulation into an open heated or *semiconditioned space* need not be separately valved (see Figure P2903.10).

Section deleted without substitution.

Proponent: Home Builders Association of South Carolina

Previous Code Cycles	Previous Modification Index Number	Previous Code Section
IRC 2018	IRC 2018 40	P2903.10
IRC 2015	IRC 2015 33	P2903.10



South Carolina Department of Labor, Licensing and Regulation
South Carolina Building Codes Council
2021 Modification Index

Applicable Code: 2021 International Residential Code

Modification Index Number: IRC 2021-62

Code Section: P2904.2.4.2.1 Additional requirements for pendant sprinklers

Modification:

P2904.2.4.2.1 Additional requirements for pendent sprinklers. Pendent sprinklers within 3 feet (915 mm) of the center of a ceiling fan, surface mounted ceiling luminaire or similar object shall be considered to be obstructed, and additional sprinklers shall be installed.

Exception: Pendant sprinklers within 3 feet (915 mm) of the center of a ceiling fan shall not be considered to be obstructed if the total area of the fan blades do not exceed more than 50 percent of the plan area view.

Proponent: South Carolina Master Plumbers Association

Previous Code Cycles	Previous Modification Index Number	Previous Code Section
N/A		



South Carolina Department of Labor, Licensing and Regulation
South Carolina Building Codes Council
2021 Modification Index

Applicable Code: 2021 International Residential Code

Modification Index Number: IRC 2021-66

Code Section: E3606.5 Surge protection

Modification:

~~**E3606.5 Surge protection.** All services supplying one- and two-family dwelling units shall be provided with a surgeprotective device (SPD) installed in accordance with Sections E3606.5.1 through E3606.5.3.~~

~~**E3606.5.1 Location.** The SPD shall be an integral part of the service equipment or shall be located immediately adjacent thereto.~~

~~**Exception:** The SPD shall not be required to be located in the service equipment if located at each next-level distribution equipment downstream toward the load.~~

~~**E3606.5.2 Type.** The SPD shall be a Type 1 or Type 2 SPD.~~

~~**E3606.5.3 Replacement.** Where service equipment is replaced, all of the requirements of this section shall apply. [230.67]~~

Proponent: Home Builders Association of South Carolina

Previous Code Cycles	Previous Modification Index Number	Previous Code Section
N/A		



South Carolina Department of Labor, Licensing and Regulation
South Carolina Building Codes Council
2021 Modification Index

Applicable Code: 2021 International Residential Code

Modification Index Number: IRC 2021-67

Code Section: E3802.4 In unfinished basements

Modification:

E3802.4 In unfinished basements and crawl spaces. Where Type NM or SE cable is run at angles with joists in unfinished basements and crawl spaces, cable assemblies containing two or more conductors of sizes 6 AWG and larger and assemblies containing three or more conductors of sizes 8 AWG and larger shall not require additional protection where attached directly to the bottom of the joists. Smaller cables shall be run either through bored holes in joists or on running boards. Type NM or SE cable installed on the wall of an unfinished basement shall be permitted to be installed in a *listed* conduit or tubing or shall be protected in accordance with Table E3802.1. Conduit or tubing shall be provided with a suitable insulating bushing or adapter at the point where the cable enters the raceway. The sheath of the Type NM or SE cable shall extend through the conduit or tubing and into the outlet or device box not less than 1/4 inch (6.4 mm). The cable shall be secured within 12 inches (305 mm) of the point where the cable enters the conduit or tubing. Metal conduit, tubing, and metal outlet boxes shall be connected to an equipment grounding conductor complying with Section E3908.14. [334.15(C)]

Proponent: Home Builders Association of South Carolina

Previous Code Cycles	Previous Modification Index Number	Previous Code Section
IRC 2018	IRC 2018 42	E3802.4
IRC 2015	IRC 2015 35	E3802.4



South Carolina Department of Labor, Licensing and Regulation
South Carolina Building Codes Council
2021 Modification Index

Applicable Code: 2021 International Residential Code

Modification Index Number: IRC 2021-69

Code Section: E3901.4.2 (1) Island and peninsular countertops and work spaces

Modification:

E3901.4.2 Island and peninsular countertops and work spaces. Receptacle outlets shall be installed in accordance with the following: [210.52(C)(2)]

1. At least one receptacle outlet shall be provided for the first ~~9 square feet~~ 6 feet (1829 mm) of length (0.84 m²), or fraction thereof, of the countertop or work surface. A receptacle outlet shall be provided for every additional 18 square feet (1.7 m²), or fraction thereof, of the countertop or work surface. [210.52(C)(2)(a)] A minimum of two receptacle outlets shall be provided for any island over 6 feet (1829 mm) long.
2. At least one receptacle outlet shall be located within 2 feet (600 mm) of the outer end of a peninsular countertop or work surface. Additional receptacle outlets shall be permitted to be located as determined by the installer, designer or building owner. The location of the receptacle outlets shall be in accordance with Section E3901.4.3. [210.52(C)(2)(b)]

Proponent: Home Builders Association of South Carolina

Previous Code Cycles	Previous Modification Index Number	Previous Code Section
N/A		



South Carolina Department of Labor, Licensing and Regulation
South Carolina Building Codes Council
2021 Modification Index

Applicable Code: 2021 International Residential Code

Modification Index Number: IRC 2021-70

Code Section: E3902 Ground-Fault and Arc-Fault Circuit-Interrupter Protection

Modification:

SECTION E3902
GROUND-FAULT AND ARC-FAULT
CIRCUIT-INTERRUPTER PROTECTION

Entire section E3902.1 - E3902.18 modified to remove “through 250 volt” from text.

Proponent: Home Builders Association of South Carolina

Previous Code Cycles	Previous Modification Index Number	Previous Code Section
N/A		



South Carolina Department of Labor, Licensing and Regulation
South Carolina Building Codes Council
2021 Modification Index

Applicable Code: 2021 International Residential Code

Modification Index Number: IRC 2021-71

Code Section: E3902.5 Basement receptacles

Modification:

E3902.5 Basement receptacles. 125-volt receptacles installed in basements and supplied by single phase branch circuits rated 150 volts or less to ground shall have ground-fault circuit-interrupter protection for personnel. [210.8(A)(5)]

Exceptions:

1. A receptacle supplying only a permanently installed fire alarm or burglar alarm system. A receptacle installed in accordance with this exception shall not be considered as meeting the requirement of Section E3901.9. Receptacles installed in accordance with this exception shall not be considered as meeting the requirement of Section E3901.9. [210.8(A)(5) Exception]

2. Receptacles in walk-out basements are excluded from this requirement.

Proponent: Home Builders Association of South Carolina

Previous Code Cycles	Previous Modification Index Number	Previous Code Section
N/A		



South Carolina Department of Labor, Licensing and Regulation
South Carolina Building Codes Council
2021 Modification Index

Applicable Code: 2021 International Residential Code

Modification Index Number: IRC 2021-73

Code Section: E3902.17 Arc-fault circuit interrupter protection

Modification:

E3902.20 Arc-fault circuit interrupter protection. In areas other than kitchen and laundry areas, branch circuits that supply 120-volt, single-phase, 15- and 20- ampere outlets installed in ~~kitchens~~, family rooms, dining rooms, living rooms, parlors, libraries, dens, bedrooms, *sunrooms*, recreations rooms, closets, hallways, ~~laundry areas~~ and similar rooms or areas shall be protected by any of the following: [210.12(A)]

(language in 1 - 6 unchanged)

*The language above has been updated as of 9-9-2022. Change of section number due to ICC-issued errata.

Proponent: Home Builders Association of South Carolina

Previous Code Cycles	Previous Modification Index Number	Previous Code Section
IRC 2018	IRC 2018 44	3902.16



South Carolina Department of Labor, Licensing and Regulation
South Carolina Building Codes Council
2021 Modification Index

Applicable Code: 2021 International Residential Code

Modification Index Number: IRC 2021-75

Code Section: E4002.14 Tamper-resistant receptacles

Modification:

E4002.14 Tamper-resistant receptacles. In areas specified in Section E3901.1, 15- and 20-ampere, 125- and 250-volt nonlocking-type receptacles shall be *listed* tamper-resistant receptacles. [406.12]

Proponent: Home Builders Association of South Carolina

Previous Code Cycles	Previous Modification Index Number	Previous Code Section
N/A		



South Carolina Department of Labor, Licensing and Regulation
South Carolina Building Codes Council
2021 Modification Index

Applicable Code: 2021 International Residential Code

Modification Index Number: IRC 2021-76

Code Section: Chapter 44 Referenced Standards

Modification:

<p>ANCE</p> <p>ANCE</p> <p>NMX-J-521/2-40-ANCE --2014/CAN/CSA-22.2 No. 60335-2-40 --12/UL-60335-2-40: Safety of Household and Similar Electric Appliances, Part 2-40: Particular Requirements for Heat Pumps, Air-Conditioners and Dehumidifiers</p> <p>M1403.1, M1412.1, M1413.1</p>	<p style="text-align: right;">Association of Standardization and Certification</p> <p style="text-align: right;">Av. Lázaro Cárdenas No. 869</p> <p style="text-align: right;">Fraccion 3</p> <p style="text-align: right;">Col. Nva. Industrial Vallejo</p> <p style="text-align: right;">Deleg. Gustavo A. Madero</p> <p style="text-align: right;">Mexico, D.F.</p>
<p>CSA</p> <p>CAN/CSA/C22.2 No. 60335-2-40 --2012 2019:</p> <p>M1402.1, M1403.1, M1412.1, M1413.1, M2006.1</p>	<p style="text-align: right;">CSA Group</p> <p style="text-align: right;">8501 East Pleasant Valley Road</p> <p style="text-align: right;">Cleveland, OH 44131-5516</p> <p style="text-align: right;">Safety of Household and Similar Electrical Appliances, Part 2-40: Particular Requirements for Electrical Heat Pumps, Air-Conditioners and Dehumidifiers <u>3rd edition</u></p>
<p>UL</p> <p>UL/CSA/ANCE 60335-2-40 --2012 2019: Standard for Household and Similar Electrical Appliances, Part 2-40: Particular Requirements for Motor-compressors Electrical Heat Pumps, Air-Conditioners and Dehumidifiers</p> <p>M1402.1, M1403.1, M1412.1, M1413.1, M2006.1</p>	<p style="text-align: right;">UL LLC</p> <p style="text-align: right;">333 Pflingsten Road</p> <p style="text-align: right;">Northbrook, IL 60062</p>

Proponent: Air-Conditioning, Heating and Refrigeration Institute (AHRI)

Previous Code Cycles	Previous Modification Index Number	Previous Code Section
N/A		



South Carolina Department of Labor, Licensing and Regulation
South Carolina Building Codes Council
2021 Modification Index

Applicable Code: 2021 International Residential Code

Modification Index Number: IRC 2021-77

Code Section: Appendix AH Patio Covers

Modification:

**APPENDIX AH
PATIO COVERS**

The provisions contained in this appendix are adopted for use statewide.

Proponent: Structural Engineers Association of South Carolina

Previous Code Cycles	Previous Modification Index Number	Previous Code Section
IRC 2018	IRC 2018 45	Appendix H
IRC 2015	IRC 2015 36	Appendix H
IRC 2012	IRC 2012 25	Appendix H



South Carolina Department of Labor, Licensing and Regulation
South Carolina Building Codes Council
2021 Modification Index

Applicable Code: 2021 International Residential Code

Modification Index Number: IRC 2021-78

Code Section: Appendix AJ Existing Buildings and Structures

Modification:

APPENDIX AJ

EXISTING BUILDINGS AND STRUCTURES

The provisions contained in this appendix are adopted for use statewide.

Proponent: Structural Engineers Association of South Carolina

Previous Code Cycles	Previous Modification Index Number	Previous Code Section
IRC 2018	IRC 2018 46	Appendix J
IRC 2015	IRC 2015 37	Appendix J



**South Carolina Department of Labor, Licensing and Regulation
South Carolina Building Codes Council
2021 Modification Index**

Applicable Code: 2021 International Residential Code

Modification Index Number: IRC 2021-79

Code Section: Appendix AQ Tiny Houses

Modification:

**APPENDIX AQ
TINY HOUSES**

The provisions contained in this appendix are adopted for use statewide.

Proponent: BOASC

Previous Code Cycles	Previous Modification Index Number	Previous Code Section
IRC 2018	IRC 2018 47	Appendix Q



South Carolina Department of Labor, Licensing and Regulation
South Carolina Building Codes Council
2021 Modification Index

Applicable Code: 2021 International Fire Code

Modification Index Number: IFC 2021-02

Code Section: 202 General definitions

Modification:

Primitive Camp Structure: Shall include any structure permanent or temporary in nature, used for outdoor camping (transient), open on at least one side with no fully enclosed habitable spaces, less than 400 square feet (37 m2) under roof, and not classified as a residential occupancy due to lack of electrical, plumbing, mechanical, and sprinkler systems.

Proponent: BOASC

Previous Code Cycles	Previous Modification Index Number	Previous Code Section
IFC 2018	IFC 2018 02	202



South Carolina Department of Labor, Licensing and Regulation
South Carolina Building Codes Council
2021 Modification Index

Applicable Code: 2021 International Fire Code

Modification Index Number: IFC 2021-03

Code Section: 202 General definitions

Modification:

[G] Assembly Group A-3. Group A-3 occupancy includes assembly uses intended for worship, recreation or amusement and other assembly uses not classified elsewhere in Group A, including, but not limited to:

- Amusement arcades
- Art galleries
- Bowling alleys
- Community halls
- Courtrooms
- Dance halls (not including food or drink consumption)
- Exhibition halls
- Funeral parlors
- Greenhouses with public access for the conservation and exhibition of plants
- Gymnasiums (without spectator seating)
- Indoor swimming pools (without spectator seating)
- Indoor tennis courts (without spectator seating) Lecture halls
- Libraries
- Museums
- Places of religious worship
- Pool and billiard parlors
- Structures without a commercial kitchen, used in agritourism activity as defined by South Carolina Code Ann. 46-53-10(1)
- Waiting areas in transportation terminals

Proponent: BOASC

Previous Code Cycles	Previous Modification Index Number	Previous Code Section
IFC 2018	IFC 2018 03	202



South Carolina Department of Labor, Licensing and Regulation
South Carolina Building Codes Council
2021 Modification Index

Applicable Code: 2021 International Fire Code

Modification Index Number: IFC 2021-04

Code Section: 202 General definitions

Modification:

RECREATIONAL FIRE. An outdoor fire burning materials other than rubbish where the fuel being burned is not contained in an incinerator, outdoor fireplace, portable outdoor fireplace, barbeque grill or barbeque pit and has a total fuel area of 3 feet (914 mm) or less in diameter and 2 feet (610 mm) or less in height for pleasure, religious, ceremonial to include sky lanterns, cooking, warmth or similar purpose.

Proponent: South Carolina Fire Marshal's Association

Previous Code Cycles	Previous Modification Index Number	Previous Code Section
IFC 2018	IFC 2018 01	202
IFC 2015	IFC 2015 01	202
IFC 2012	IFC 2012 01	202



South Carolina Department of Labor, Licensing and Regulation
South Carolina Building Codes Council
2021 Modification Index

Applicable Code: 2021 International Fire Code

Modification Index Number: IFC 2021-05

Code Section: 315.3.3 Equipment rooms

Modification:

315.3.3 Equipment rooms. Combustible Material shall not be stored in boiler rooms, mechanical rooms, **elevator machine rooms**, electrical equipment rooms or in *fire command centers* as specified in Section 508.1.5. Rooms shall be labeled with approved signage “No storage allowed”.

*The language above has been updated as of 9-9-2022 and the scrivener's error has been corrected.

Proponent: Midlands Fire Marshal's Association

Previous Code Cycles	Previous Modification Index Number	Previous Code Section
N/A		



South Carolina Department of Labor, Licensing and Regulation
South Carolina Building Codes Council
2021 Modification Index

Applicable Code: 2021 International Fire Code

Modification Index Number: IFC 2021-07

Code Section: 319.11 Clearance requirements

Modification:

319.11 Mobile cooking operations. Mobile cooking operations shall be separated from buildings, structures, canopies, tents, combustible materials, vehicles, and other cooking operations by a minimum of 10 feet (3048 mm). Exhaust shall be directed away from openings, air intakes and away from any means of egress.

Proponent: Midlands Fire Marshal's Association

Previous Code Cycles	Previous Modification Index Number	Previous Code Section
N/A		



South Carolina Department of Labor, Licensing and Regulation
South Carolina Building Codes Council
2021 Modification Index

Applicable Code: 2021 International Fire Code

Modification Index Number: IFC 2021-08

Code Section: 503.1.2 Additional access

Modification:

503.1.2 Additional access. The *fire code official* is authorized to require more than one fire apparatus access road based on the potential for impairment of a single road by vehicle congestion, condition of terrain, climatic conditions or other factors that could limit access.

Exception: Where two fire apparatus access roads are required by Section 503.1.2 ~~or this appendix~~, the additional fire apparatus access road is permitted to be a driveway, pathway, court or other approved *fire lane* not accessible to public motor vehicles where designed by a registered design professional to meet the loading requirements and minimum specifications of Section 503 ~~and this appendix~~, and the surface provides all-weather driving capabilities. Marking or signs shall be provided in accordance with Section 503.3 and Section D103.6.

*The language above has been updated as of 8-25-2022 and the previous reference to Appendix D was a scrivener's error.

Proponent: Home Builders Association of South Carolina

Previous Code Cycles	Previous Modification Index Number	Previous Code Section
N/A		



South Carolina Department of Labor, Licensing and Regulation
South Carolina Building Codes Council
2021 Modification Index

Applicable Code: 2021 International Fire Code

Modification Index Number: IFC 2021-09

Code Section: 503.1.2.1

Modification:

503.1.2.1 One- or two-family dwelling residential developments having less than 50 units. Developments of one- or two-family dwellings where the number of dwelling units does not exceed 50 shall be permitted to have a single approved fire apparatus access road provided all of the following requirements are met.

1. The minimum unobstructed width of the single fire apparatus access road shall be 26 feet (7925 mm) and shall otherwise comply with Section 503.
2. A minimum of one fire hydrant on each side of the fire apparatus access road in accordance with Section 507.5 shall be provided. The fire code official shall be permitted to require additional hydrants and hydrant spacing based on the length of the fire apparatus access road, fire flow requirements, and the distance from any point on the street or road frontage to a hydrant.
3. The development is not located in a wildland-urban interface area as defined in the International Wildland-Urban Interface Code.

503.1.2.1 Future development. The number of dwelling units on a single fire apparatus access road shall not be increased unless fire apparatus access roads will connect with future development, as determined by the *fire code official*.

Proponent: Home Builders Association of South Carolina

Previous Code Cycles	Previous Modification Index Number	Previous Code Section
N/A		



South Carolina Department of Labor, Licensing and Regulation
South Carolina Building Codes Council
2021 Modification Index

Applicable Code: 2021 International Fire Code

Modification Index Number: IFC 2021-10

Code Section: 503.2.1 Dimensions

Modification:

503.2.1 Dimensions. Fire apparatus access roads shall have an unobstructed width of not less than 20 feet (6096 mm) ~~exclusive of shoulders~~, except for approved security gates in accordance with Section 503.6 and an unobstructed vertical clearance of not less than 13 feet 6 inches (4115 mm).

Proponent: Home Builders Association of South Carolina

Previous Code Cycles	Previous Modification Index Number	Previous Code Section
IFC 2018	IFC 2018 05	503.2.1
IFC 2015	IFC 2015 04	503.2.1
IFC 2012	IFC 2012 04	503.2.1



South Carolina Department of Labor, Licensing and Regulation
South Carolina Building Codes Council
2021 Modification Index

Applicable Code: 2021 International Fire Code

Modification Index Number: IFC 2021-11

Code Section: 507.1 Required water supply

Modification:

507.1 Required water supply. An approved water supply capable of supplying the required fire flow for fire protection shall be provided to premises on which facilities, buildings or portions of buildings are hereafter constructed or moved into or within the jurisdiction to meet the necessary fire flow as determined by the fire code official. Where public water supply is inadequate or not available, an approved alternative water source meeting the fire flow requirements shall be provided. Fire flow performance tests shall be witnessed by the fire official or representative prior to final approval.

Exception: One- and two-family dwellings, including attached or detached accessory structures.

Proponent: Charleston Fire Department

Previous Code Cycles	Previous Modification Index Number	Previous Code Section
IFC 2018	IFC 2018 06	507.1



South Carolina Department of Labor, Licensing and Regulation
South Carolina Building Codes Council
2021 Modification Index

Applicable Code: 2021 International Fire Code

Modification Index Number: IFC 2021-12

Code Section: 507.5.1 Where Required

Modification:

507.5.1 Where required. Where a portion of the facility or building hereafter constructed or moved into or within the jurisdiction is more than ~~400 feet (122 m)~~ 500 feet (152m) from a hydrant on a fire apparatus access road, as measured by an approved route around the exterior of the facility or building, on-site fire hydrants and mains shall be provided where required by the fire code official.

Location. The location and number of hydrants shall be designated by the fire official, but in no case shall the distance between installed fire hydrants exceed 1000 feet (305 m). Fire hydrants shall be located within 500 feet (152 m) of all fire fighter access points when measured along the normal routes of fire department vehicle access which conforms to the requirements of Section 503. No point of the exterior of a building shall be located more than 500 feet (152 m) from a hydrant accessible to fire department vehicles as provided in Section 503.

Exceptions:

1. For Group R-3 and Group U occupancies, the distance requirement shall be 600 feet (183 m).
2. For buildings equipped throughout with an approved automatic sprinkler system installed in accordance with Section 903.3.1.1 or 903.3.1.2, the distance requirement shall be 600 feet (183 m).

Proponent: Charleston Fire Department

Previous Code Cycles	Previous Modification Index Number	Previous Code Section
IFC 2018	IFC 2018 07	507.5.1



South Carolina Department of Labor, Licensing and Regulation
South Carolina Building Codes Council
2021 Modification Index

Applicable Code: 2021 International Fire Code

Modification Index Number: IFC 2021-13

Code Section: 507.5.1.1 Hydrant for standpipe systems

Modification:

507.5.1.1 Hydrant for standpipe systems. Buildings equipped with a standpipe or fire sprinkler system installed in accordance with Section 903 or 905 shall have a fire hydrant within 100 feet (30 480 mm) of the fire department connections.

Exception: The distance shall be permitted to exceed 100 feet (30 480 mm) where *approved* by the *fire code official*.

Proponent: Midlands Fire Marshal's Association

Previous Code Cycles	Previous Modification Index Number	Previous Code Section
N/A		



South Carolina Department of Labor, Licensing and Regulation
South Carolina Building Codes Council
2021 Modification Index

Applicable Code: 2021 International Fire Code

Modification Index Number: IFC 2021-14

Code Section: 507.5.4 Obstruction

Modification:

507.5.4 Obstruction. Unobstructed access to fire hydrants shall be maintained at all times. The fire department shall not be deterred or hindered from gaining immediate access to fire protection equipment or fire hydrants. No parking shall be allowed within 15 feet (4572 mm) of a fire hydrant.

Proponent: Midlands Fire Marshal's Association

Previous Code Cycles	Previous Modification Index Number	Previous Code Section
N/A		



South Carolina Department of Labor, Licensing and Regulation
South Carolina Building Codes Council
2021 Modification Index

Applicable Code: 2021 International Fire Code

Modification Index Number: IFC 2021-16

Code Section: 607.1 General

Modification:

607.1 General. Storage of cooking oil (grease) in commercial cooking operations utilizing above-ground tanks with a capacity greater than 60 gal (227 L) installed within a building shall comply with Sections 607.2 through 607.7 and NFPA 30. For purposes of this section, cooking oil shall be classified as a Class IIIB liquid unless otherwise determined by testing. These tanks shall have the contents identified as outlined in Section 5703.5.

Proponent: Midlands Fire Marshal's Association

Previous Code Cycles	Previous Modification Index Number	Previous Code Section
N/A		



South Carolina Department of Labor, Licensing and Regulation
South Carolina Building Codes Council
2021 Modification Index

Applicable Code: 2021 International Fire Code

Modification Index Number: IFC 2021-19

Code Section: 901.6.3 Records

Modification:

901.6.3 Records. Records of all system inspections, tests and maintenance required by the referenced standards shall be maintained. Copies of the inspection reports shall be sent to the local jurisdiction by the servicing vendor as prescribed by the fire code official.

Proponent: Charleston Fire Department

Previous Code Cycles	Previous Modification Index Number	Previous Code Section
IFC 2018	IFC 2018 08	901.6.3



South Carolina Department of Labor, Licensing and Regulation
South Carolina Building Codes Council
2021 Modification Index

Applicable Code: 2021 International Fire Code

Modification Index Number: IFC 2021-22

Code Section: 907.6.5 Access

Modification:

907.6.5 Access. Access shall be provided to each fire alarm device and notification appliance for periodic inspection, maintenance and testing. Fire alarm notification devices shall be unobstructed and visible at all times.

Proponent: Midlands Fire Marshal's Association

Previous Code Cycles	Previous Modification Index Number	Previous Code Section
N/A		



South Carolina Department of Labor, Licensing and Regulation
South Carolina Building Codes Council
2021 Modification Index

Applicable Code: 2021 International Fire Code

Modification Index Number: IFC 2021-24

Code Section: 1010.2.14 Controlled egress doors in Groups I-1 and I-2

Modification:

[BE] 1010.2.14 Controlled egress doors in Groups I-1, I-2 and I-4 (Adult Day Care occupancy only). Electric locking systems, including electromechanical locking systems and electromagnetic locking systems, shall be permitted to be locked in the means of egress in Group I-1, I-2 and I-4 (Adult Day Care occupancy only) occupancies where the clinical needs of persons receiving care require their containment. Controlled egress doors shall be permitted in such occupancies where the building is equipped throughout with an *automatic sprinkler system* in accordance with Section 903.3.1.1 or an *approved* automatic smoke detection system installed in accordance with Section 907, provided that the doors are installed and operate in accordance with all of the following:

1. The door locks shall unlock on actuation of the automatic sprinkler system or automatic smoke detection system.
2. The door locks shall unlock on loss of power controlling the lock or lock mechanism.
3. The door locking system shall be installed to have the capability of being unlocked by a switch located at the fire command center, a nursing station or other approved location. The switch shall directly break power to the lock.
4. A building occupant shall not be required to pass through more than one door equipped with a controlled egress locking system before entering an exit.
5. The procedures for unlocking the doors shall be described and approved as part of the emergency planning and preparedness required by Chapter 4.
6. All clinical staff shall have the keys, codes or other means necessary to operate the locking systems.
7. Emergency lighting shall be provided at the door.
8. The door locking system units shall be listed in accordance with UL 294.

Exceptions:

1. Items 1 through 4 shall not apply to doors to areas occupied by persons who, because of clinical needs, require restraint or containment as part of the function of a psychiatric or cognitive treatment area.
2. Items 1 through 4 shall not apply to doors to areas where a listed egress control system is utilized to reduce the risk of child abduction from nursery and obstetric areas of a Group I-2 hospital.

Proponent: Midlands Fire Marshal's Association

Previous Code Cycles	Previous Modification Index Number	Previous Code Section
N/A		



South Carolina Department of Labor, Licensing and Regulation
South Carolina Building Codes Council
2021 Modification Index

Applicable Code: 2021 International Fire Code

Modification Index Number: IFC 2021-25

Code Section: 1016.2 Egress through intervening spaces

Modification:

1016.2 Egress through intervening spaces. Egress through intervening spaces shall comply with this section.

1. Exit access through an enclosed elevator lobby is permitted. Where access to two or more exits or exit access doorways is required in Section 1006.2.1, access to not less than one of the required exits shall be provided without travel through the enclosed elevator lobbies required by Section 3006 of the South Carolina Building Code. Where the path of exit access travel passes through an enclosed elevator lobby, the level of protection required for the enclosed elevator lobby is not required to be extended to the exit unless direct access to an exit is required by other sections of this code.
2. Egress from a room or space shall not pass through adjoining or intervening rooms or areas, except where such adjoining rooms or areas and the area served are accessory to one or the other, are not a Group H occupancy and provide a discernible path of egress travel to an exit.

 Exception: Means of egress are not prohibited through adjoining or intervening rooms or spaces in a Group H, S or F occupancy where the adjoining or intervening rooms or spaces are the same or a lesser hazard occupancy group.
3. An exit access shall not pass through a room that can be locked to prevent egress.
4. Means of egress from dwelling units or sleeping areas shall not lead through other sleeping areas, toilet rooms or bathrooms.

 Exception: Dwelling units or sleeping areas in R-1 and R-2 occupancies shall be permitted to egress through other sleeping areas serving adjoining rooms that are part of the same dwelling unit or guest room.
5. Egress shall not pass through kitchens, storage rooms, closets or spaces used for similar purposes.

 Exceptions:
 1. Means of egress are not prohibited through a kitchen area serving adjoining rooms constituting part of the same dwelling unit or sleeping unit.
 2. Means of egress are not prohibited through stockrooms in Group M occupancies where all of the following are met:
 - 2.1. The stock is of the same hazard classification as that found in the main retail area.
 - 2.2. Not more than 50 percent of the exit access is through the stockroom.
 - 2.3. The stockroom is not subject to locking from the egress side.
 - 2.4. There is a demarcated, minimum 44-inch-wide (1118 mm) aisle defined by ~~full- or partial-height fixed walls~~ a wall not less than 42 inches (1066 mm) high or similar construction that will maintain the required width and lead directly from the retail area to the exit without obstructions.

Proponent: Charleston Fire Department

Previous Code Cycles	Previous Modification Index Number	Previous Code Section
IFC 2018	IFC 2018 11	1016.2



South Carolina Department of Labor, Licensing and Regulation
South Carolina Building Codes Council
2021 Modification Index

Applicable Code: 2021 International Fire Code

Modification Index Number: IFC 2021-31

Code Section: 2303.2.2 Testing

Modification:

2303.2.2 Testing. Emergency disconnect switches shall be tested annually by the responsible party to ensure proper operation; records of testing shall be maintained on site for inspection. For any switches determined to be faulty, the fuel pumps they serve shall be taken out of service until the emergency shutoff switch is placed back into service.

Proponent: Midlands Fire Marshal's Association

Previous Code Cycles	Previous Modification Index Number	Previous Code Section
N/A		



South Carolina Department of Labor, Licensing and Regulation
South Carolina Building Codes Council
2021 Modification Index

Applicable Code: 2021 International Fire Code

Modification Index Number: IFC 2021-33

Code Section: 2305.5 Fire extinguishers

Modification:

2305.5 Fire extinguishers. *Approved* portable fire extinguishers complying with Section 906 with a minimum rating of 2-A:20-B:C shall be provided and located such that an extinguisher is not more than ~~75 feet (22 860 mm)~~ 50 feet (15 240 mm) from pumps, dispensers or storage tank fill-pipe openings.

Proponent: Midlands Fire Marshal's Association

Previous Code Cycles	Previous Modification Index Number	Previous Code Section
N/A		



South Carolina Department of Labor, Licensing and Regulation
South Carolina Building Codes Council
2021 Modification Index

Applicable Code: 2021 International Fire Code

Modification Index Number: IFC 2021-34

Code Section: 2307.4 Location of dispensing operations and equipment

Modification:

2307.4 Location of dispensing operations and equipment. The point of transfer for LP-gas dispensing operations shall be separated from buildings and other exposures in accordance with NFPA 58 Table 6.7.2.1 and IFC Section 2306.7, the following:

1. Not less than 25 feet (7620 mm) from buildings where the exterior wall is not part of a fire-resistance-rated assembly having a rating of 1 hour or greater.
2. Not less than 25 feet (7620 mm) from combustible overhangs on buildings, measured from a vertical line dropped from the face of the overhang at a point nearest the point of transfer.
3. Not less than 25 feet (7620 mm) from the lot line of property that can be built on.
4. Not less than 25 feet (7620 mm) from the centerline of the nearest mainline railroad track.
5. Not less than 10 feet (3048 mm) from public streets, highways, thoroughfares, sidewalks and driveways.
6. Not less than 10 feet (3048 mm) from buildings where the exterior wall is part of a fire-resistance-rated assembly having a rating of 1 hour or greater.

Exception: The point of transfer for LP-gas dispensing operations need not be separated from canopies that are constructed in accordance with the South Carolina Building Code and that provide weather protection for the dispensing equipment.

LP-Gas containers shall be located in accordance with Chapter 61. LP-gas storage and dispensing equipment shall be located outdoors and in accordance with Section 2306.7.

Proponent: South Carolina Propane Gas Association

Previous Code Cycles	Previous Modification Index Number	Previous Code Section
IFC 2018	IFC 2018 12	2307.4
IFC 2015	IFC 2015 09	2307.4
IFC 2012	IFC 2012 09	2307.4



South Carolina Department of Labor, Licensing and Regulation
South Carolina Building Codes Council
2021 Modification Index

Applicable Code: 2021 International Fire Code

Modification Index Number: IFC 2021-35

Code Section: 2307.7 Public fueling of motor vehicles

Modification:

2307.7 Public fueling of motor vehicles. Self-service LP-gas dispensing systems, including key, code and card lock dispensing systems, shall be limited to the filling of permanently mounted containers providing fuel to the LP-gas powered vehicle.

The requirements for self-service LP-gas dispensing systems shall be in accordance with the following:

1. The arrangement and operation of the transfer of product into a vehicle shall be in accordance with this section and Chapter 61.
2. The system shall be provided with an emergency shutoff switch located within 100 feet (30 480 mm) of, but not less than 20 feet (6096 mm) from, dispensers.
3. The owner of the LP-gas motor fuel-dispensing facility or the owner's designee shall provide for the safe operation of the system and the training of users.
4. The dispenser and hose-end valve shall release not more than 1/8 fluid ounce (4 cc) of liquid to the atmosphere upon breaking the connection with the fill valve on the vehicle.
5. Portable fire extinguishers shall be provided in accordance with Section 2305.5.
6. Warning signs shall be provided in accordance with Section 2305.6.
7. The area around the dispenser shall be maintained in accordance with Section 2305.7.

Proponent: South Carolina Propane Gas Association

Previous Code Cycles	Previous Modification Index Number	Previous Code Section
IFC 2018	IFC 2018 13	2307.7
IFC 2015	IFC 2015 11	2307.7
IFC 2012	IFC 2012 11	2307.6



South Carolina Department of Labor, Licensing and Regulation
South Carolina Building Codes Council
2021 Modification Index

Applicable Code: 2021 International Fire Code

Modification Index Number: IFC 2021-38

Code Section: 6101.1 Scope

Modification:

6101.1 Scope. Storage, handling and transportation of liquefied petroleum gas (LP-gas) and the installation of LP-gas equipment pertinent to systems for such uses shall comply with this chapter and NFPA 58. Properties of LP-gases shall be determined in accordance with ~~Appendix~~ Annex B of NFPA 58.

Proponent: South Carolina Fire Marshal's Association

Previous Code Cycles	Previous Modification Index Number	Previous Code Section
IFC 2018	IFC 2018 14	6101.1
IFC 2015	IFC 2015 12	6101.1
IFC 2012	IFC 2012 12	6101.1



South Carolina Department of Labor, Licensing and Regulation
South Carolina Building Codes Council
2021 Modification Index

Applicable Code: 2021 International Fire Code

Modification Index Number: IFC 2021-41

Code Section: 6106.1 Attendants

Modification:

6106.1 Attendants. Dispensing of LP-gas shall be performed by a qualified attendant that meets the requirements of this section and NFPA 58 Section 4.4.

Proponent: South Carolina Fire Marshal's Association

Previous Code Cycles	Previous Modification Index Number	Previous Code Section
IFC 2018	IFC 2018 17	6106.1
IFC 2015	IFC 2015 16	6106.1
IFC 2012	IFC 2012 16	6106.1



South Carolina Department of Labor, Licensing and Regulation
South Carolina Building Codes Council
2021 Modification Index

Applicable Code: 2021 International Fire Code

Modification Index Number: IFC 2021-42

Code Section: 6107.4 Protecting containers from vehicles

Modification:

6107.4 Protecting containers from vehicles. Where exposed to vehicular damage due to proximity to alleys, driveways or parking areas, LP-gas containers, regulators and piping shall be protected in accordance with NFPA 58.

Exception: An alternative method may be used that meets the intent of this section with the approval of the authority having jurisdiction (AHJ).

Proponent: South Carolina Fire Marshal's Association

Previous Code Cycles	Previous Modification Index Number	Previous Code Section
IFC 2018	IFC 2018 18	6107.4
IFC 2015	IFC 2015 18	6107.4
IFC 2012	IFC 2012 18	6107.4



South Carolina Department of Labor, Licensing and Regulation
South Carolina Building Codes Council
2021 Modification Index

Applicable Code: 2021 International Fire Code

Modification Index Number: IFC 2021-43

Code Section: 6109.13 Protection of containers

Modification:

6109.13 Protection of containers. LP-gas containers shall be stored within a suitable enclosure or otherwise protected against tampering. Vehicle impact protection shall be provided as required by ~~Section 6107.4.~~ the fire code official in accordance with Section 312 or NFPA Section 58 8.4.2.2.

Exception: Vehicle impact protection shall not be required for protection of LP-gas containers where the containers are kept in lockable, ventilated cabinets of metal construction.

Proponent: South Carolina Fire Marshal's Association

Previous Code Cycles	Previous Modification Index Number	Previous Code Section
IFC 2018	IFC 2018 20	6109.13
IFC 2015	IFC 2015 22	6109.13
IFC 2012	IFC 2012 22	6109.13



South Carolina Department of Labor, Licensing and Regulation
South Carolina Building Codes Council
2021 Modification Index

Applicable Code: 2021 International Fire Code

Modification Index Number: IFC 2021-44

Code Section: 6110.1 Removed from service

Modification:

6110.1 Removed from service Containers not connected for service at customer locations. LP-gas containers at customers' locations that are not connected for service whose use has been discontinued shall comply with both all of the following:

1. — Be disconnected from appliance piping.
- 2.1. Have LP-gas container outlets, except relief valves, closed and or plugged or capped.
- 3.2. Be positioned with the relief valve in direct communication with the LP-gas container vapor space.

Proponent: SC Fire Marshal's Association

Previous Code Cycles	Previous Modification Index Number	Previous Code Section
IFC 2018	IFC 2018 21	6110.1
IFC 2015	IFC 2015 23	6110.1
IFC 2012	IFC 2012 23	6110.1



South Carolina Department of Labor, Licensing and Regulation
South Carolina Building Codes Council
2021 Modification Index

Applicable Code: 2021 International Fire Code

Modification Index Number: IFC 2021-45

Code Section: 6111.2.1

Modification:

6111.2.1 Near residential, educational and institutional occupancies and other high-risk areas. LP-gas tank vehicles shall not be left unattended at any time on residential streets or within 500 feet (152 m) of a residential area, apartment or hotel complex, educational facility, hospital or care facility. Tank vehicles shall not be left unattended at any other place that would, in the opinion of the *fire code official*, pose an extreme life hazard.

Separation distance requirements may be reduced to not less than 50 feet as *approved* by the *fire code official*, based upon a completed fire safety analysis and consideration of special features such as topographical conditions, capacity of the LP-gas vehicle and the capabilities of the local fire department. The Office of the State Fire Marshal will provide an *approved* fire safety analysis to be utilized for this specific requirement.

Proponent: South Carolina Fire Marshal's Association

Previous Code Cycles	Previous Modification Index Number	Previous Code Section
IFC 2018	IFC 2018 22	6111.2.1
IFC 2015	IFC 2015 24	6111.2.1
IFC 2012	IFC 2012 24	6111.2.1



South Carolina Department of Labor, Licensing and Regulation
South Carolina Building Codes Council
2021 Modification Index

Applicable Code: 2021 International Plumbing Code

Modification Index Number: IPC 2021-01

Code Section: 202 General Definitions

Modification:

DRINKING FOUNTAIN. A plumbing fixture that is connected to the potable water distribution system and the drainage system. The fixture allows the user to obtain a drink directly from a stream of flowing water without the use of any accessories. Such fixtures can be separate from or integral to a bottle-filling station.

Proponent: Carolinas AGC

Previous Code Cycles	Previous Modification Index Number	Previous Code Section
N/A		



South Carolina Department of Labor, Licensing and Regulation
South Carolina Building Codes Council
2021 Modification Index

Applicable Code: 2021 International Plumbing Code

Modification Index Number: IPC 2021-02

Code Section: 202 General Definitions

Modification:

BOTTLE-FILLING STATION. A type of water dispenser that is connected to the potable water distribution system and the drainage system. The fixture is designed and intended for automatically or manually filling personal use drinking water bottles or containers not less than 10 inches (254 mm) in height and is in compliance with the Americans with Disabilities Act (42 U.S.C. § 12101 et seq.). Such fixtures can be separate from or integral to a drinking fountain and can incorporate a water filter and a cooling system for chilling the drinking water.

Proponent: Carolinas AGC

Previous Code Cycles	Previous Modification Index Number	Previous Code Section
N/A		



South Carolina Department of Labor, Licensing and Regulation
South Carolina Building Codes Council
2021 Modification Index

Applicable Code: 2021 International Plumbing Code

Modification Index Number: IPC 2021-03

Code Section: 202 General Definitions

Modification:

WATER COOLER. A drinking fountain or bottle-filling station that incorporates a means of reducing the temperature of the water supplied to it from the potable water distribution system.

Proponent: Carolinas AGC

Previous Code Cycles	Previous Modification Index Number	Previous Code Section
N/A		



South Carolina Department of Labor, Licensing and Regulation
South Carolina Building Codes Council
2021 Modification Index

Applicable Code: 2021 International Plumbing Code

Modification Index Number: IPC 2021-04

Code Section: 202 General Definitions

Modification:

WATER DISPENSER. A plumbing fixture that is automatic or manually controlled by the user for the purpose of dispensing potable drinking water into a receptacle such as a cup, glass or bottle. Such fixture is connected to the potable water distribution system of the premises. This definition includes a free-standing apparatus for the same purpose that is not connected to the potable water distribution system and that is supplied with potable water from a container, bottle or reservoir.

Proponent: Carolinas AGC

Previous Code Cycles	Previous Modification Index Number	Previous Code Section
N/A		



South Carolina Department of Labor, Licensing and Regulation
South Carolina Building Codes Council
2021 Modification Index

Applicable Code: 2021 International Plumbing Code

Modification Index Number: IPC 2021-05

Code Section: Table 403.1 Minimum Number of Required Plumbing Fixtures

Modification:

Add column to table - BOTTLE FILLING STATION

Row 3 Educational, under Bottle Filling Station column. add: 1 per 200 with placement of 1 on each floor (or wing, or other building section) and 1 in school food service areas

See Attachment

Proponent: Carolinas AGC

Previous Code Cycles	Previous Modification Index Number	Previous Code Section
N/A		

Table 403.1
Minimum Number of Required Plumbing Fixtures^a (See Sections 403.1.1 and 403.2)

No.	Classification	Description	Water Closets (Urinals: See Section 424.2)		Lava- to-ries		Bathtubs/ Showers	Drinking Fountain (See Section 410)	Other	Bottle Filling Station
			M	F	M	F				
3	Educational	Educational Facilities	1 per 50		1 per 50		-	1 per 100	1 service sink	<u>1 per 200 with placement of 1 on each floor (or wing or other building section) and 1 in school food service areas.</u>



South Carolina Department of Labor, Licensing and Regulation
South Carolina Building Codes Council
2021 Modification Index

Applicable Code: 2021 International Plumbing Code

Modification Index Number: IPC 2021-06

Code Section: 410.4 Substitution

Modification:

410.4 Substitution. Where restaurants provide drinking water in a container free of charge, drinking fountains shall not be required in those restaurants. In other *occupancies* where three or more drinking fountains are required, *water dispensers* shall be permitted to be substituted for not more than 50 percent of the required number of drinking fountains. In educational settings, 50 percent of the required number of drinking fountains must incorporate a bottle-filling station.

Proponent: Carolinas AGC

Previous Code Cycles	Previous Modification Index Number	Previous Code Section
N/A		



South Carolina Department of Labor, Licensing and Regulation
South Carolina Building Codes Council
2021 Modification Index

Applicable Code: 2021 International Mechanical Code

Modification Index Number: IMC 2021-01

Code Section: 504.9.2 Duct Installation

Modification:

504.9.2 Duct installation. Exhaust ducts shall be supported at intervals not to exceed 8 feet and within 16 inches of each side of a joint that is not installed in a vertical orientation, ~~4-foot (1219 mm) intervals and~~ secured in place, making rigid contact with the duct at not less than 4 equally spaced points or 2/3rds contact if strap is used. All brackets and strapping must be noncombustible. The insert end of the duct shall extend into the adjoining duct or fitting in the direction of airflow. ~~Ducts shall not be joined with screws or similar fasteners that protrude more than 1/8 inch (3.2 mm) into the inside of the duct. The overlap shall comply with Section 603.4.2. Ducts shall not be joined with screws or similar devices that protrude into the inside of the duct.~~ Exhaust ducts shall be sealed in accordance with Section 603.9.

Where dryer exhaust ducts are enclosed in wall or ceiling cavities, such cavities shall allow the installation of the duct without deformation. The duct work may be ovalized as long as it terminates in an approved duct box. Minor imperfections located on the duct, in areas other than along the seam, do not constitute a violation of this section.

Proponent: Building Official Association of South Carolina (BOASC)

Previous Code Cycles	Previous Modification Index Number	Previous Code Section
IMC 2018	IMC 2018 01	504.8.2



South Carolina Department of Labor, Licensing and Regulation
South Carolina Building Codes Council
2021 Modification Index

Applicable Code: 2021 International Mechanical Code

Modification Index Number: IMC 2021-02

Code Section: Table 1103.1 Refrigerant Classification Amount and OEL

Modification:

Footnote:
 c. The ASHRAE Standard 34 flammability classification for this refrigerant is 2L, which is a subclass of Class 2.

Proponent: Air Conditioning, Heating, Refrigeration Institute (AHRI)

Previous Code Cycles	Previous Modification Index Number	Previous Code Section
N/A		



South Carolina Department of Labor, Licensing and Regulation
South Carolina Building Codes Council
2021 Modification Index

Applicable Code: 2021 International Mechanical Code

Modification Index Number: IMC 2021-03

Code Section: 1104.3 System Application Requirements

Modification:

1104.3.1 Air conditioning for human comfort. High probability systems used for human comfort shall use Group A1 or A2L refrigerant. In other than industrial *occupancies* where the quantity in a single independent circuit does not exceed the amount in Table 1103.1, Group B1, B2 and B3 refrigerants shall not be used in high-probability systems for air conditioning for human comfort.

Proponent: Air Conditioning, Heating, Refrigeration Institute (AHRI)

Previous Code Cycles	Previous Modification Index Number	Previous Code Section
N/A		



South Carolina Department of Labor, Licensing and Regulation
South Carolina Building Codes Council
2021 Modification Index

Applicable Code: 2021 International Mechanical Code

Modification Index Number: IMC 2021-04

Code Section: Chapter 15 Referenced Standards

Modification:

CSA	<u>C22.2 No. 60335-2-40--2019 Household and Similar Electrical Appliances - Safety - Part 2_40: Particular Requirements for Electrical Heat Pumps, Air-Conditioners and Dehumidifiers - 3rd Edition</u>
	<u>908.1, 916.1, 918.2, 1101.2</u>
UL	
<u>60335-2-40-17 2019</u>	<u>Household and Similar Electrical Appliances - Safety - Part 2_40: Particular Requirements for Electrical Heat Pumps, Air-Conditioners and Dehumidifiers</u>
	<u>908.1, 916.1, 918.1, 918.2, 1101.2</u>

Proponent: Air Conditioning, Heating, Refrigeration Institute (AHRI)

Previous Code Cycles	Previous Modification Index Number	Previous Code Section
N/A		



South Carolina Department of Labor, Licensing and Regulation
South Carolina Building Codes Council
2021 Modification Index

Applicable Code: 2021 International Fuel Gas Code

Modification Index Number: IFGC 2021-01

Code Section: 401.9 Identification

Modification:

401.9 Identification. Each length of pipe and tubing and each pipe fitting, utilized in a fuel gas system, shall bear the identification of the manufacturer.

Exceptions:

1. Steel pipe sections that are 2 feet (610 mm) and less in length and are cut from longer sections of pipe.
2. Steel pipe fittings 2 inches and less in size.
3. Where identification is provided on the product packaging or crating.
4. Where other *approved* documentation is provided.

Section deleted without substitution.

Proponent: South Carolina Propane Gas Association (SCPGA)

Previous Code Cycles	Previous Modification Index Number	Previous Code Section
IFGC 2018	IFGC 2018 01	401.9
IFGC 2015	IFGC 2015 01	401.9
IFGC 2012	IFGC 2012 01	401.9



South Carolina Department of Labor, Licensing and Regulation
South Carolina Building Codes Council
2021 Modification Index

Applicable Code: 2021 International Fuel Gas Code

Modification Index Number: IFGC 2021-02

Code Section: 401.10 Third-Party Testing and Certification

Modification:

401.10 Piping materials standards. Piping, tubing and fittings shall be manufactured to the applicable referenced standards, specifications and performance criteria listed in Section 403 and shall be identified in accordance with Section 401.9. **Third-party testing and certification.** All piping, tubing and fittings shall comply with the applicable referenced standards, specifications and performance criteria of this code, including Section 403 of the South Carolina Fuel Gas Code and corresponding sections.

Proponent: South Carolina Propane Gas Association (SCPGA)

Previous Code Cycles	Previous Modification Index Number	Previous Code Section
IFGC 2018	IFGC 2018 02	401.10
IFGC 2015	IFGC 2015 02	401.10
IFGC 2012	IFGC 2012 02	401.10



South Carolina Department of Labor, Licensing and Regulation
South Carolina Building Codes Council
2021 Modification Index

Applicable Code: 2021 International Fuel Gas Code

Modification Index Number: IFGC 2021-03

Code Section: 412.4 Listed Equipment

Modification:

[F] 412.4 Listed equipment. Hoses, hose connections, vehicle fuel connections, dispensers, LP-gas pumps and electrical equipment used for LP-gas shall comply with the requirements of NFPA 58 *be listed*.

Proponent: South Carolina Propane Gas Association (SCPGA)

Previous Code Cycles	Previous Modification Index Number	Previous Code Section
IFGC 2018	IFGC 2018 03	412.4
IFGC 2015	IFGC 2015 03	412.4
IFGC 2012	IFGC 2012 03	412.4



South Carolina Department of Labor, Licensing and Regulation
South Carolina Building Codes Council
2021 Modification Index

Applicable Code: 2021 International Fuel Gas Code

Modification Index Number: IFGC 2021-04

Code Section: 412.6 Location

Modification:

[F] 412.6 Location. The point of transfer for LP-gas dispensing operations shall be separated from buildings and other exposures in accordance with the following:

1. Not less than 25 feet (7620 mm) from buildings where the exterior wall is not part of a fire-resistance-rated assembly having a rating of 1 hour or greater.
2. Not less than 25 feet (7620 mm) from combustible overhangs on buildings, measured from a vertical line dropped from the face of the overhang at a point nearest the point of transfer.
3. Not less than 25 feet (7620 mm) from the lot line of property that can be built upon.
4. Not less than 25 feet (7620 mm) from the centerline of the nearest mainline railroad track.
5. Not less than 10 feet (3048 mm) from public streets, highways, thoroughfares, sidewalks and driveways.
6. Not less than 10 feet (3048 mm) from buildings where the exterior wall is part of a fire-resistance-rated assembly having a rating of 1 hour or greater.

In addition to the fuel dispensing requirements of the South Carolina Fire Code, the point of transfer for dispensing operations shall be 25 feet (7620 mm) or more from buildings having combustible exterior wall surfaces, buildings having noncombustible exterior wall surfaces that are not part of a 1-hour fire-resistance-rated assembly or buildings having combustible overhangs, property that could be built on and railroads; at least 10 feet (3048 mm) from public streets or sidewalks and buildings having noncombustible exterior wall surfaces that are part of a fire-resistance-rated assembly having a rating of 1 hour or more; and 5 feet (1524 mm) from driveways.

Exceptions:

1. The point of transfer for LP-gas dispensing operations need not be separated from canopies providing weather protection for the dispensing equipment that are constructed in accordance with the International Building Code and that provide weather protection for the dispensing equipment. Liquefied petroleum gas containers shall be located in accordance with the International Fire Code.
2. The separation from driveways is not required where the driveway serves the vehicle fuel dispenser.

Liquefied petroleum gas containers shall be located in accordance with the International Fire Code. Liquefied petroleum gas storage and dispensing equipment shall be located outdoors and in accordance with the International South Carolina Fire Code.

Proponent: South Carolina Propane Gas Association (SCPGA)

Previous Code Cycles	Previous Modification Index Number	Previous Code Section
IFGC 2018	IFGC 2018 04	412.6
IFGC 2015	IFGC 2015 04	412.6
IFGC 2012	IFGC 2012 04	412.6



South Carolina Department of Labor, Licensing and Regulation
South Carolina Building Codes Council
2021 Modification Index

Applicable Code: 2021 International Fuel Gas Code

Modification Index Number: IFGC 2021-05

Code Section: 412.8.3 Vehicle Impact Protection

Modification:

[F] 412.8.3 Vehicle impact protection. Where installed within 10 feet (3048 mm) of vehicle traffic, LP-gas storage containers, pumps and dispensers shall be protected in accordance with Section 2307.5, Item 2 of the International Fire Code.

Exception: An alternative method may be used that meets the intent of this section with the approval of the authority having jurisdiction (AHJ).

Proponent: South Carolina Propane Gas Association

Previous Code Cycles	Previous Modification Index Number	Previous Code Section
IFGC 2018	IFGC 2018 06	412.8.3
IFGC 2015	IFGC 2015 05	412.8.3
IFGC 2012	IFGC 2012 05	412.7.3



South Carolina Department of Labor, Licensing and Regulation
South Carolina Building Codes Council
2021 Modification Index

Applicable Code: 2021 International Fuel Gas Code

Modification Index Number: IFGC 2021-06

Code Section: 412.10 Private fueling of motor vehicles

Modification:

412.10 Private fueling of motor vehicles. Self-service LP-gas dispensing systems, including key, code and card lock dispensing systems, shall not be open to the public. In addition to the requirements of the South Carolina Fire Code, self-service LP-gas dispensing systems shall be provided with an emergency shutoff switch located within 100 feet (30 480 mm) of, but not less than 20 feet (6096 mm) from, dispensers, and the owner of the dispensing facility shall ensure the safe operation of the system and the training of users.

Proponent: South Carolina Propane Gas Association (SCPGA)

Previous Code Cycles	Previous Modification Index Number	Previous Code Section
IFGC 2018	IFGC 2018 07	412.10
IFGC 2015	IFGC 2015 06	412.10
IFGC 2012	IFGC 2012 06	412.8



South Carolina Department of Labor, Licensing and Regulation
South Carolina Building Codes Council
2021 Modification Index

Applicable Code: 2021 International Fuel Gas Code

Modification Index Number: IFGC 2021-07

Code Section: 505.1.1 Commercial cooking appliances vented by exhaust hoods

Modification:

505.1.1 Commercial cooking appliances vented by exhaust hoods. Where commercial cooking appliances are vented by means of the Type I or II kitchen exhaust hood system that serves such appliances, the exhaust system shall be fan powered and the appliances shall be interlocked with the exhaust hood system to prevent appliance operation when the exhaust hood system is not operating. ~~The method of interlock between the exhaust hood system and the appliances equipped with standing pilot burner ignition systems shall not cause such pilots to be extinguished.~~ Where a solenoid valve is installed in the gas piping as part of an interlock system, gas piping shall not be installed to bypass such valve. Dampers shall not be installed in the exhaust system.

Exception: An interlock between the cooking appliance(s) and the exhaust hood system shall not be required for appliances that are of the manually operated type and are factory equipped with standing pilot burner ignition systems. ~~where heat sensors or other approved methods automatically activate the exhaust hood system when cooking operations occur.~~

Proponent: Piedmont Natural Gas

Previous Code Cycles	Previous Modification Index Number	Previous Code Section
IFGC 2018	IFGC 2018 08	505.1.1
IFGC 2015	IFGC 2015 07	505.1.1
IFGC 2012	IFGC 2012 07	505.1.1
IFGC 2006	IFGC 2006 01	505.1.1
IFGC 2003 & 2000	IFGC 2003 02,IFGC 2000 02	505.1.1



South Carolina Department of Labor, Licensing and Regulation
South Carolina Building Codes Council
2021 Modification Index

Applicable Code: 2020 National Electrical Code

Modification Index Number: NEC 2020-03

Code Section: 210.8(A)(5) Dwelling Units

Modification:

210.8(A) Dwelling Units. All 125-volt ~~through 250-volt~~ receptacles installed in the locations specified in 210.8(A)(1) through (A)(11) and supplied by single-phase branch circuits rated 150 volts or less to ground shall have ground-fault circuit-interrupter protection for personnel.

- (1) Bathrooms.
- (2) Garages and also accessory buildings that have a floor located at or below grade level not intended as habitable rooms and limited to storage areas, work areas, and areas of similar use.
- (3) Outdoors.
Exception to (3): Receptacles that are not readily accessible and are supplied by a branch circuit dedicated to electric snow-melting, deicing, or pipeline and vessel heating equipment shall be permitted to be installed in accordance with 426.28 or 427.22, as applicable.
- (4) Crawl spaces - at or below grade level.
- (5) Basements
Exception No. 1 to (5): A receptacle supplying only a permanently installed fire alarm or burglar alarm system shall not be required to have ground-fault circuit-interrupter protection.
Exception No. 2 to (5): Receptacles in walk-out basements are excluded from this requirement.

Receptacles installed under the exception to 210.8(A)(5) shall not be considered as meeting the requirements of 210.52(G).

- (6) Kitchens - where the receptacles are installed to serve the countertop surfaces.
- (7) Sinks - where receptacles are installed within 1.8 m (6 ft) from the top inside edge of the bowl of the sink.
- (8) Boathouses.
- (9) Bathtubs or shower stalls - where receptacles are installed within 1.8 m (6 ft) of the outside edge of the bathtub or shower stall.
- (10) Laundry areas.
Exception to (1) through (3), (5) through (8), and (10): Listed locking support and mounting receptacles utilized in combination with compatible attachment fittings installed for the purpose of serving a ceiling luminaire or ceiling fan shall not be required to be ground-fault circuit-interrupter protected. If a general-purpose convenience receptacle is integral to the ceiling luminaire or ceiling fan, GFCI protection shall be provided.
- (11) Indoor damp and wet locations.

Proponent: Home Builders Association of South Carolina

Previous Code Cycles	Previous Modification Index Number	Previous Code Section
N/A		



South Carolina Department of Labor, Licensing and Regulation
South Carolina Building Codes Council
2021 Modification Index

Applicable Code: 2020 National Electrical Code

Modification Index Number: NEC 2020-04

Code Section: 210.8(F) Outdoor Outlets

Modification:

210.8(F) Outdoor Outlets. All outdoor outlets for dwellings, other than those covered in 210.8(A)(3), Exception to (3), that are supplied by single-phase branch circuits rated 150 volts to ground or less, 50 amperes or less, shall have ground-fault circuit-interrupter protection for personnel.

Exception: Ground-fault circuit-interrupter protection shall not be required on lighting outlets other than those covered in 210.8(C).

Proponent: Home Builders Association of South Carolina

Previous Code Cycles	Previous Modification Index Number	Previous Code Section
N/A		



South Carolina Department of Labor, Licensing and Regulation
South Carolina Building Codes Council
2021 Modification Index

Applicable Code: 2020 National Electrical Code

Modification Index Number: NEC 2020-05

Code Section: 210.12(A) Dwelling Units

Modification:

210.12(A) Dwelling Units. All 120_volt, single_phase, 15_ and 20_ ampere branch circuits supplying outlets or devices installed in dwelling unit ~~kitchens~~; family rooms, dining rooms, living rooms, parlors, libraries, dens, bedrooms, sunrooms, recreation rooms, closets, hallways, ~~laundry areas~~, or similar rooms or areas shall be protected by any of the means described in 210.12(A)(1) through (6):

Items (1) through (6) and Exception to remain as written.

Proponent: Home Builders Association of South Carolina

Previous Code Cycles	Previous Modification Index Number	Previous Code Section
N/A		



South Carolina Department of Labor, Licensing and Regulation
South Carolina Building Codes Council
2021 Modification Index

Applicable Code: 2020 National Electrical Code

Modification Index Number: NEC 2020-06

Code Section: 230.67 Surge Protection

Modification:

230.67 Surge Protection.

~~(A) Surge-Protective Device.~~ All services supplying dwelling units shall be provided with a surge-protective device (SPD).

~~(B) Location.~~ The SPD shall be an integral part of the service equipment or shall be located immediately adjacent thereto.

Exception: The SPD shall not be required to be located in the service equipment as required in (B) if located at each next level distribution equipment downstream toward the load.

~~(C) Type.~~ The SPD shall be a Type 1 or Type 2 SPD.

~~(D) Replacement.~~ Where service equipment is replaced, all of the requirements of this sections shall apply.

This section is deleted without substitution.

Proponent: Home Builders Association of South Carolina

Previous Code Cycles	Previous Modification Index Number	Previous Code Section
N/A		